

Quantum Spintronics Design (NV centers in diamond)

Eisuke Abe

RIKEN Center for Quantum Computing

2021.9.8

CMD Spintronics Design Course
(Online)



Diamond envy

III (13)	IV (14)	V (15)
B	C	N



©GIA

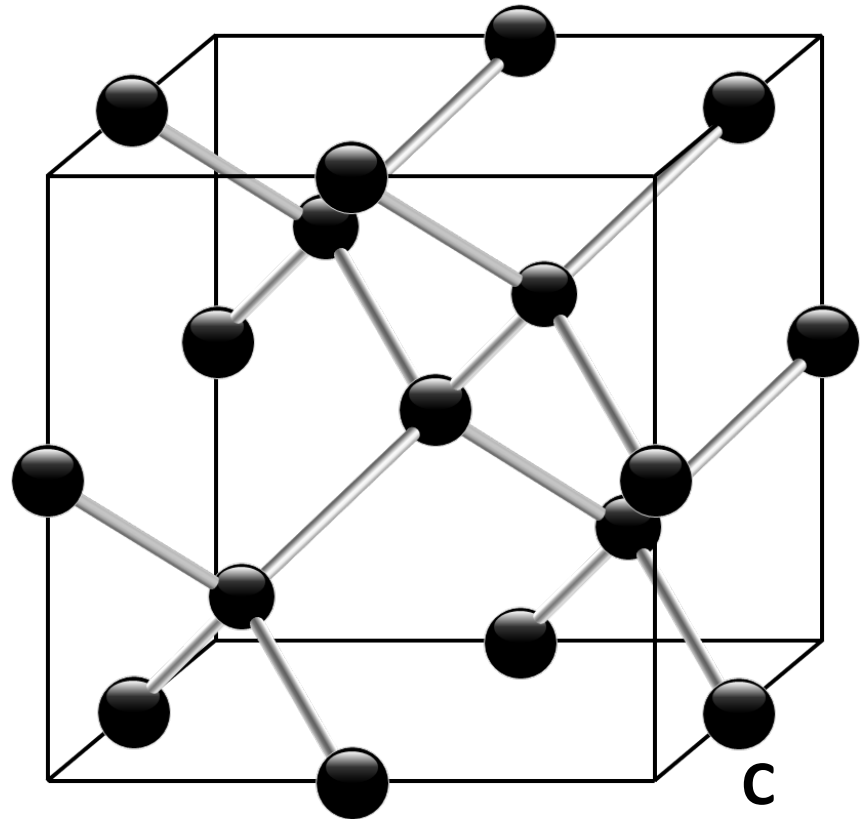

$$\rho_N = 1.77 \times 10^{23} \text{ cm}^{-3}$$

Diamond envy

III (13)	IV (14)	V (15)
B	C	N



©GIA

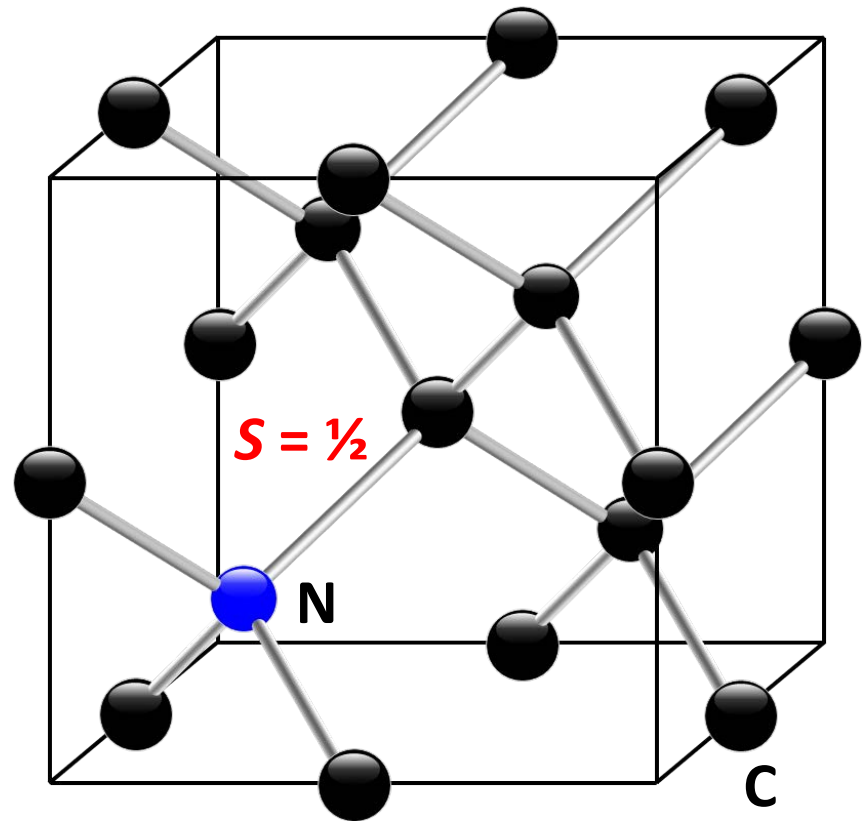

$$\rho_N = 1.77 \times 10^{23} \text{ cm}^{-3}$$

Diamond NV

III (13)	IV (14)	V (15)
B	C	N

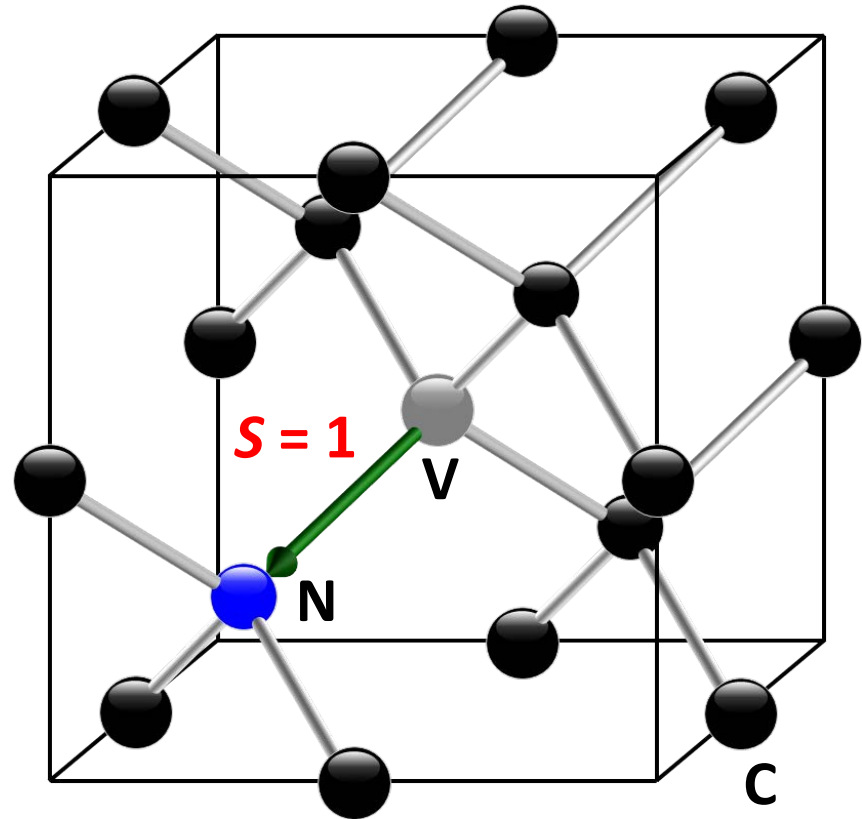

$$\rho_N = 1.77 \times 10^{23} \text{ cm}^{-3}$$



©GIA

Diamond NV

Synthetic (CVD) diamond
2² x 0.5 mm³, \$700 (E6)
[N] < 5 ppb, [NV] < 0.03 ppb

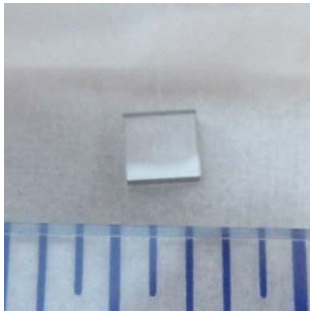

Not like...



©GIA

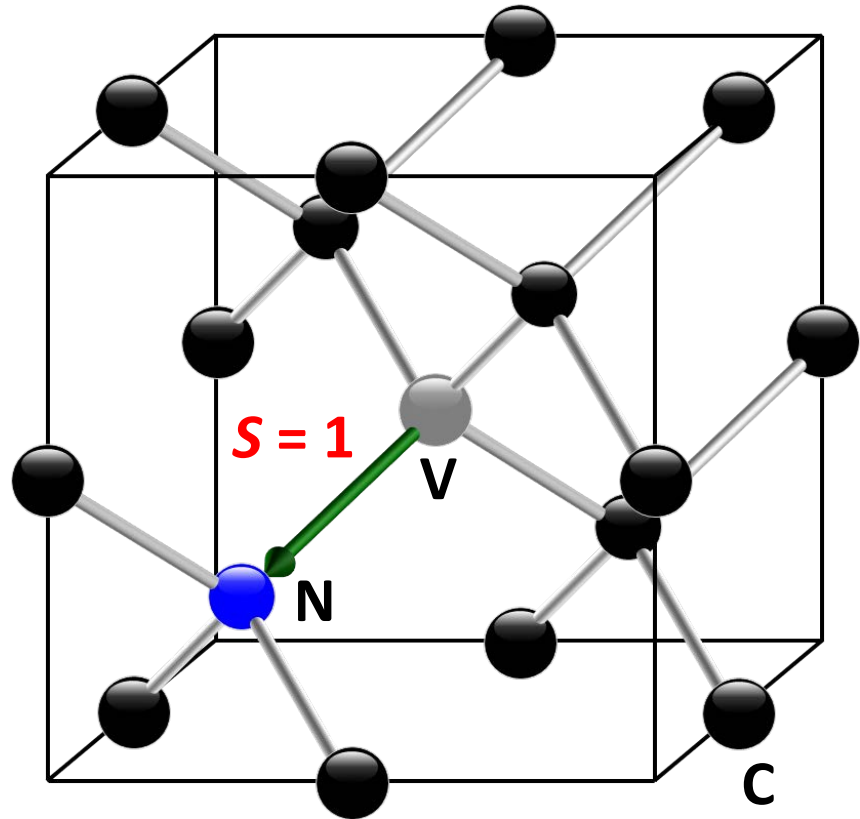

$$\rho_N = 1.77 \times 10^{23} \text{ cm}^{-3}$$

Quantum sensing with NV centers

- B , E , T , S ...
- DC & AC modes
- Wide temperature range
- Nondestructive
- High spatial resolution
- Various modalities

Nanodiamond & biology

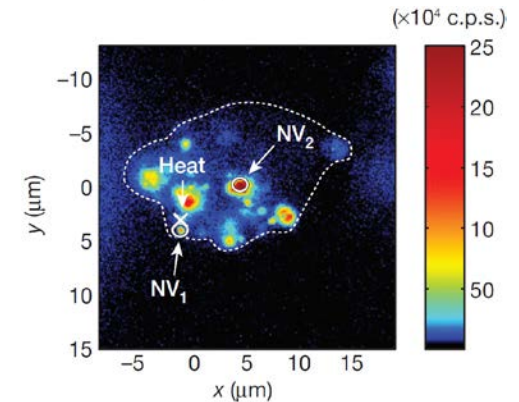
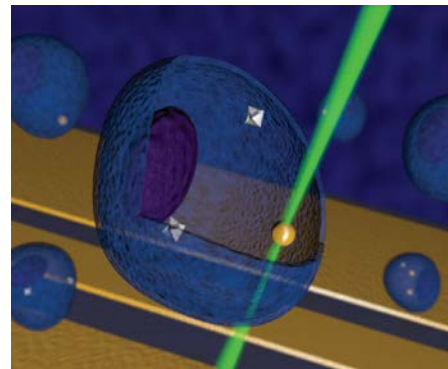

Nature **500**, 54 (2013)

Near-surface NV center & NMR

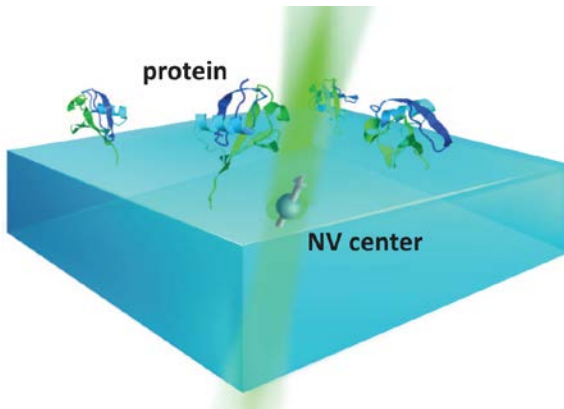

Science **351**, 836 (2016)

Scanning probe & condensed matter

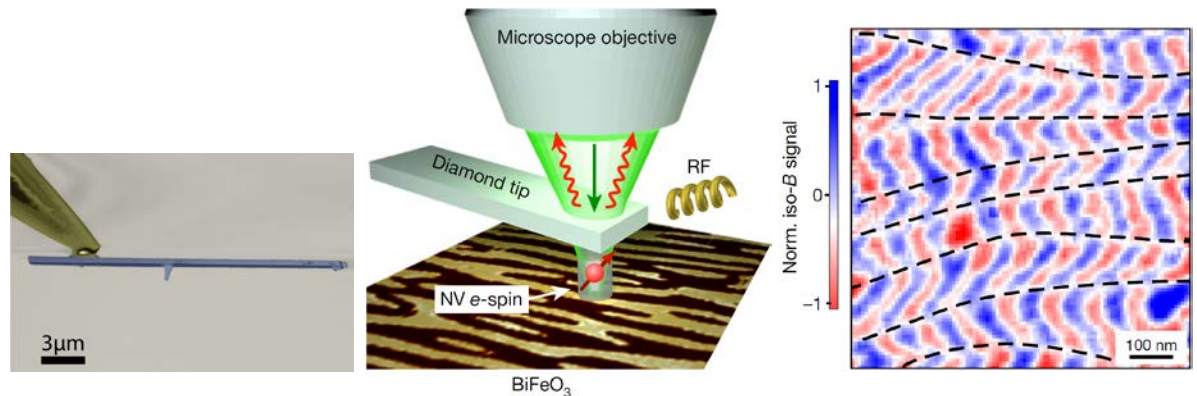

Rev. Sci. Instrum. **87**, 063703 (2016); Nature **549**, 252 (2017)

Outline

- **Basics of NV centers in diamond**
 - Structure
 - Optical & magnetic properties
- **Basics of magnetic resonance**
- **Quantum sensing**
 - AC magnetometry
 - Detection of proton spin ensemble
 - Detection and control of a single proton spin

Outline

- **Basics of NV centers in diamond**
 - Structure
 - Optical & magnetic properties
- **Basics of magnetic resonance**
- **Quantum sensing**
 - AC magnetometry
 - Detection of proton spin ensemble
 - Detection and control of a single proton spin

Crystal & energy level structures

- Negatively-charged (NV^-)
- 4 sp^3 orbitals, 6 e^- (5 from the defect, 1 captured)
- C_{3v} (symmetry axis = quantization axis)

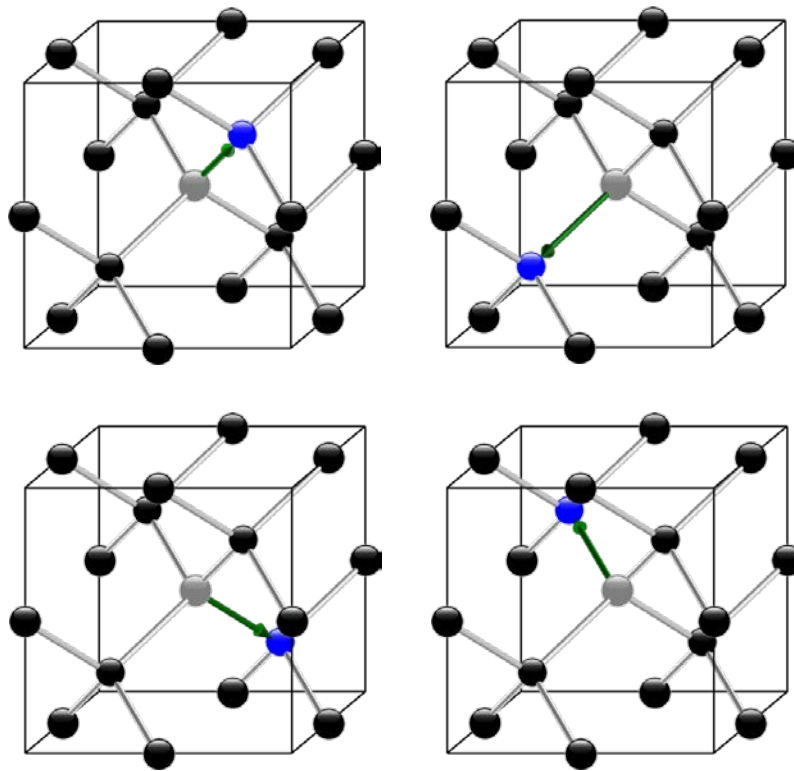

Effective spin-1 system
(e^2 -hole spin-triplet)

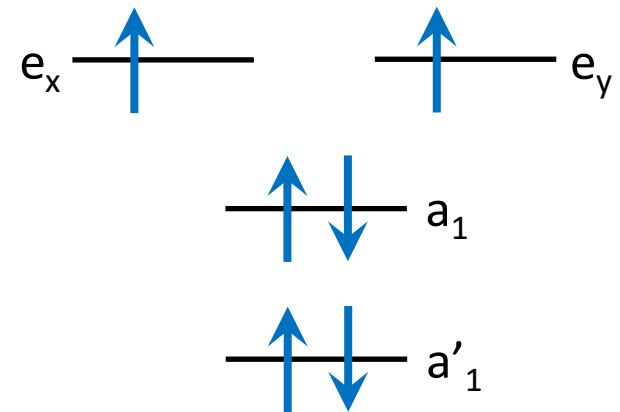

Energy levels

C.B. ($E_g = 5.47 \text{ eV} = 227 \text{ nm}$)

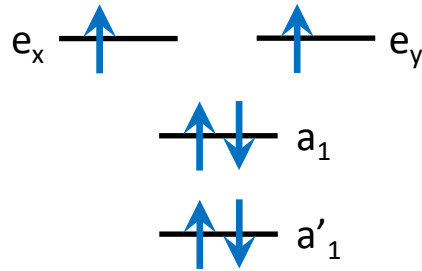
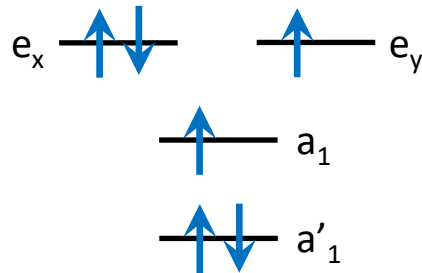
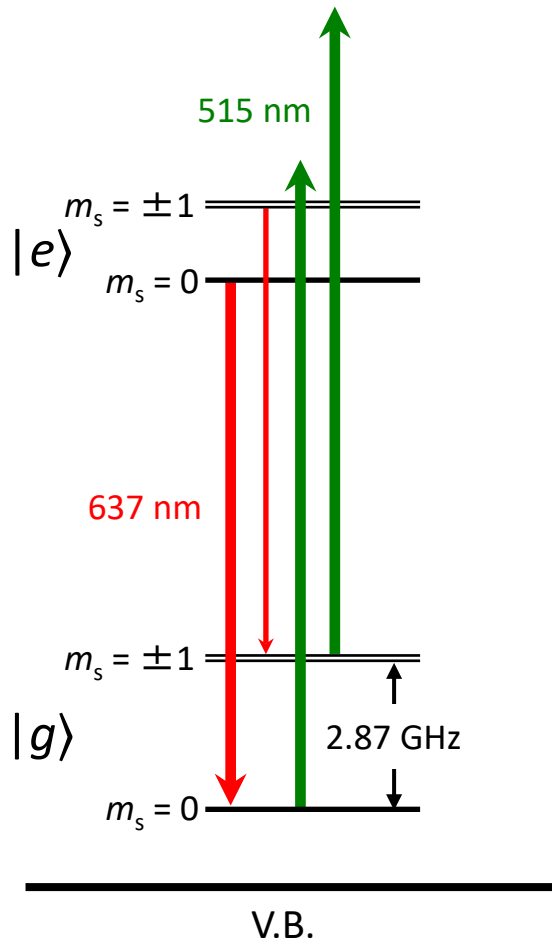

PL spectroscopy & imaging

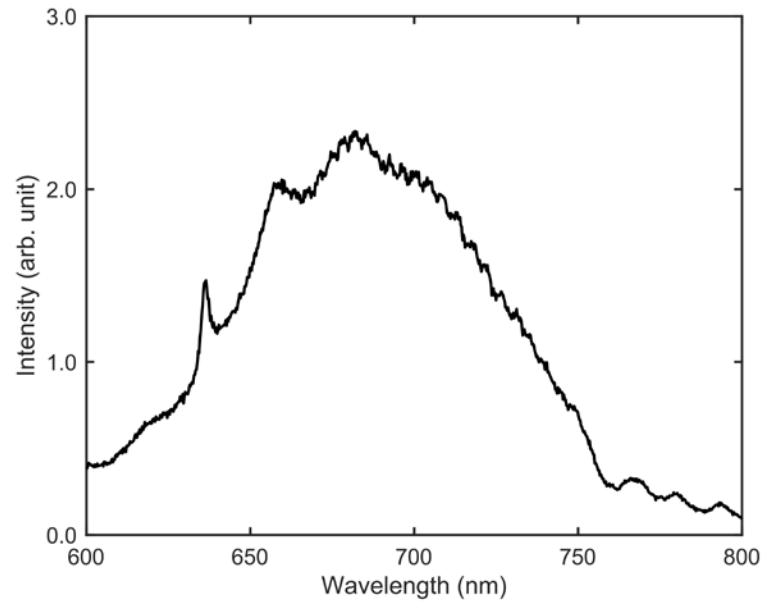
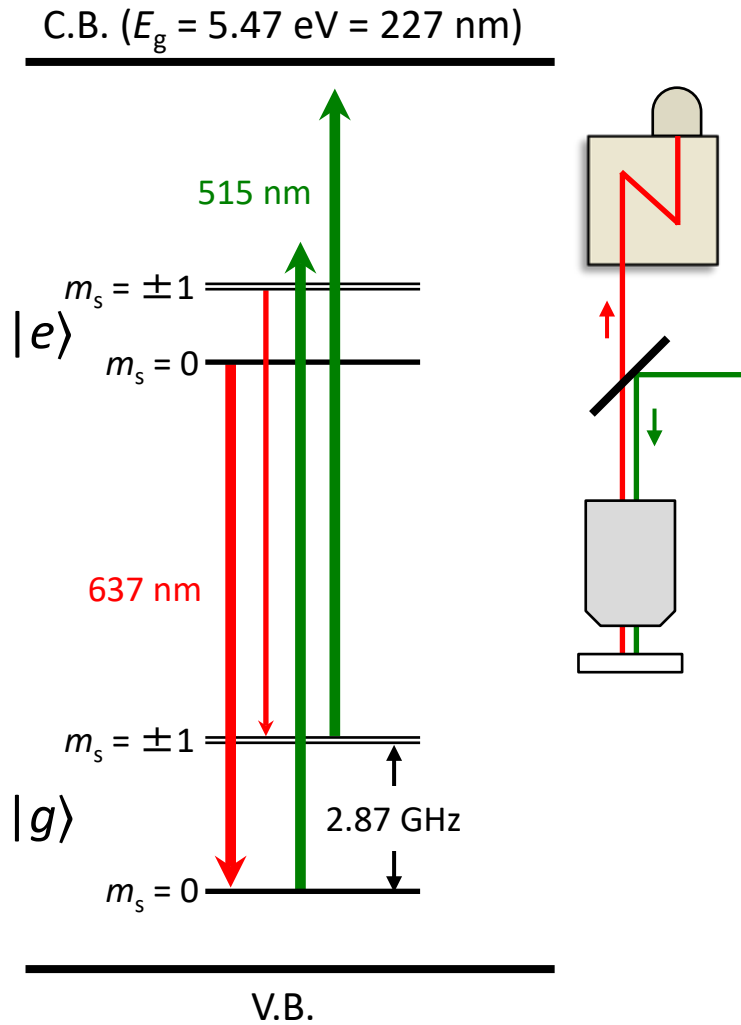

PL spectroscopy & imaging

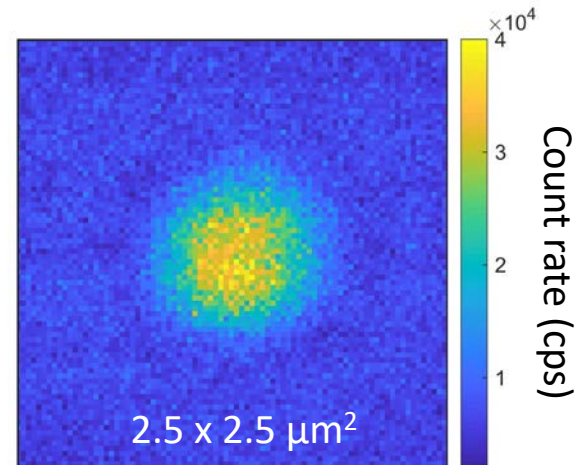
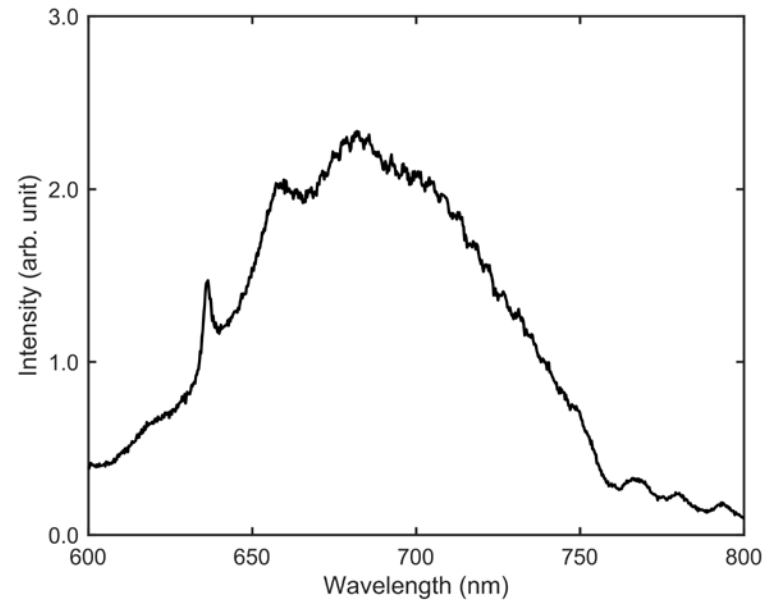
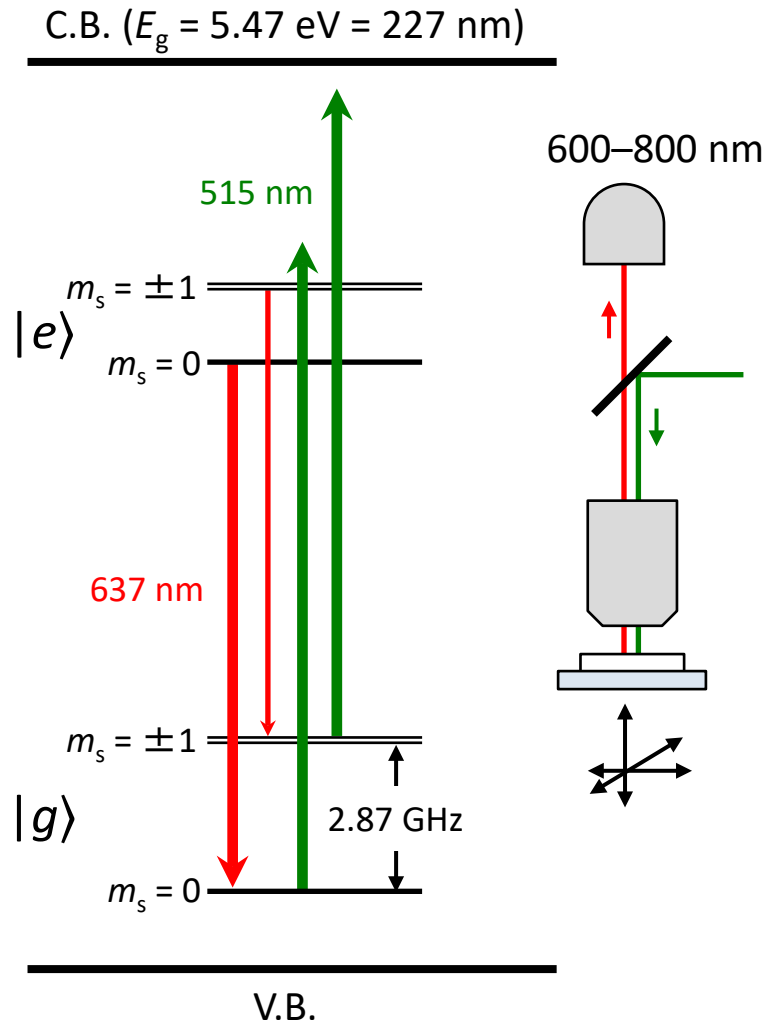

Photon statistics

C.B. ($E_g = 5.47 \text{ eV} = 227 \text{ nm}$)

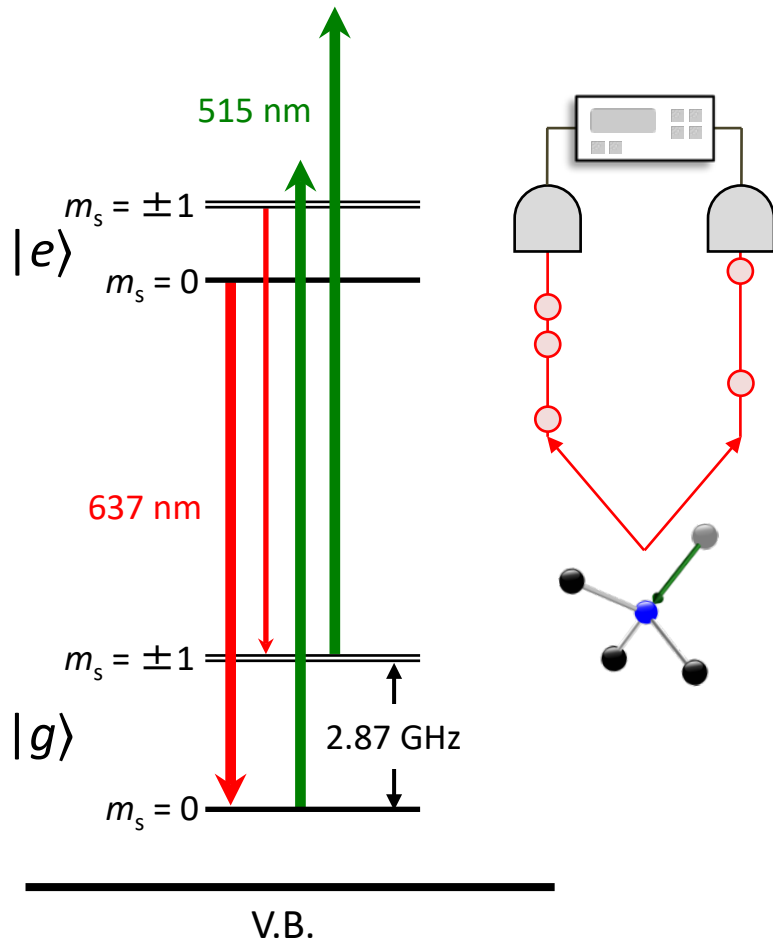

One photon at a time

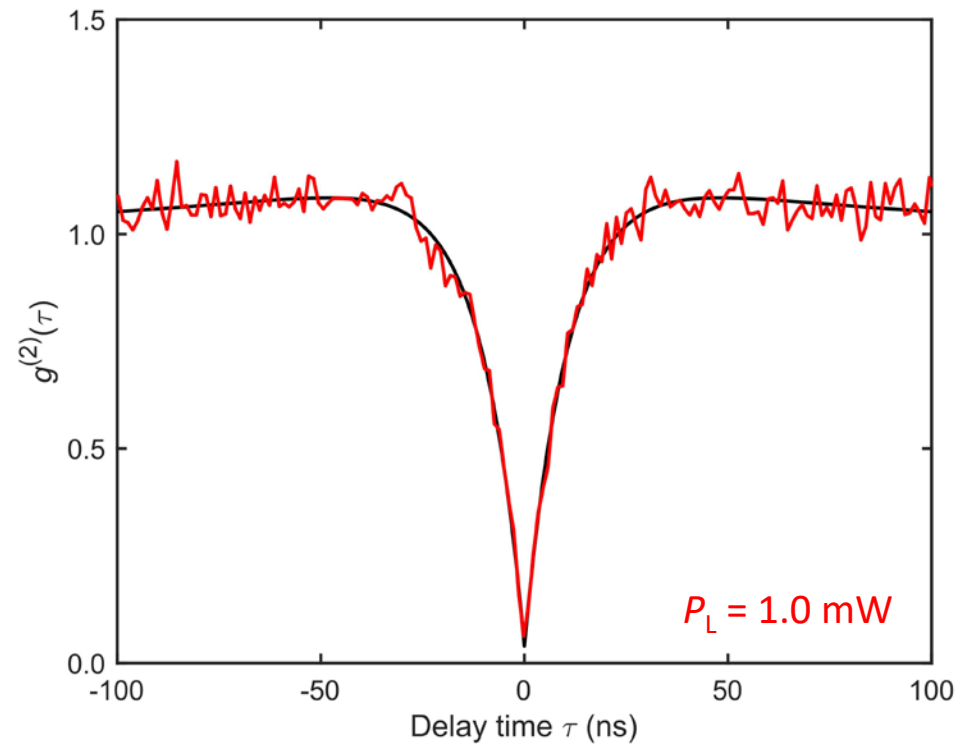

Time-resolved fluorescence

C.B. ($E_g = 5.47 \text{ eV} = 227 \text{ nm}$)

The **non-radiative & spin-selective** channel provides a means to **read out & initialize** the NV spin

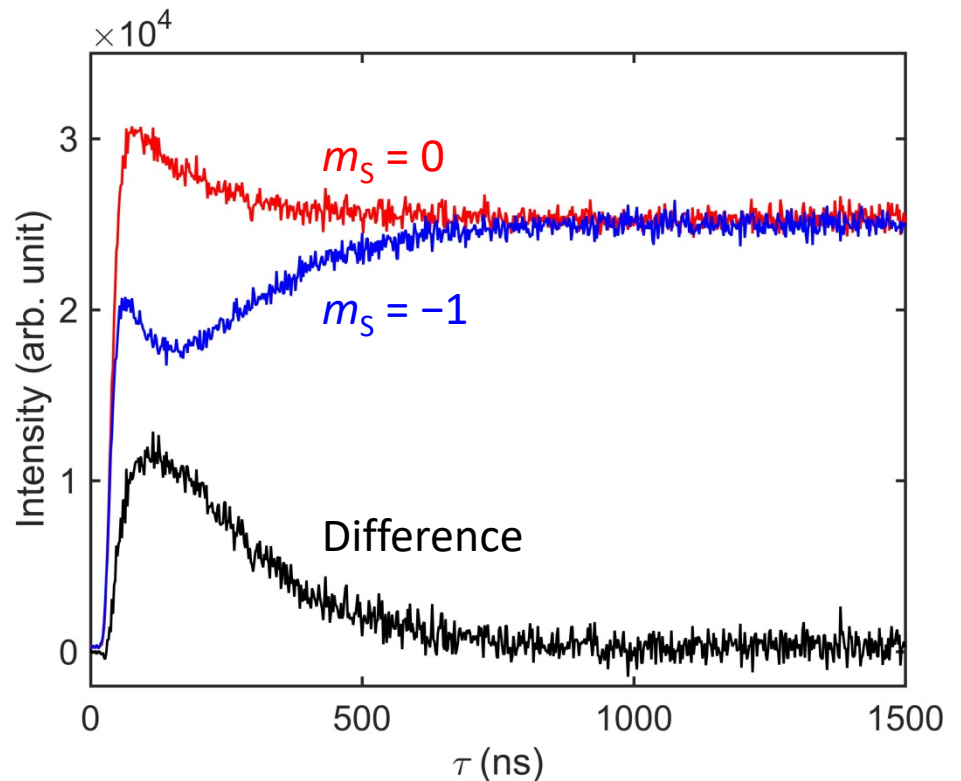
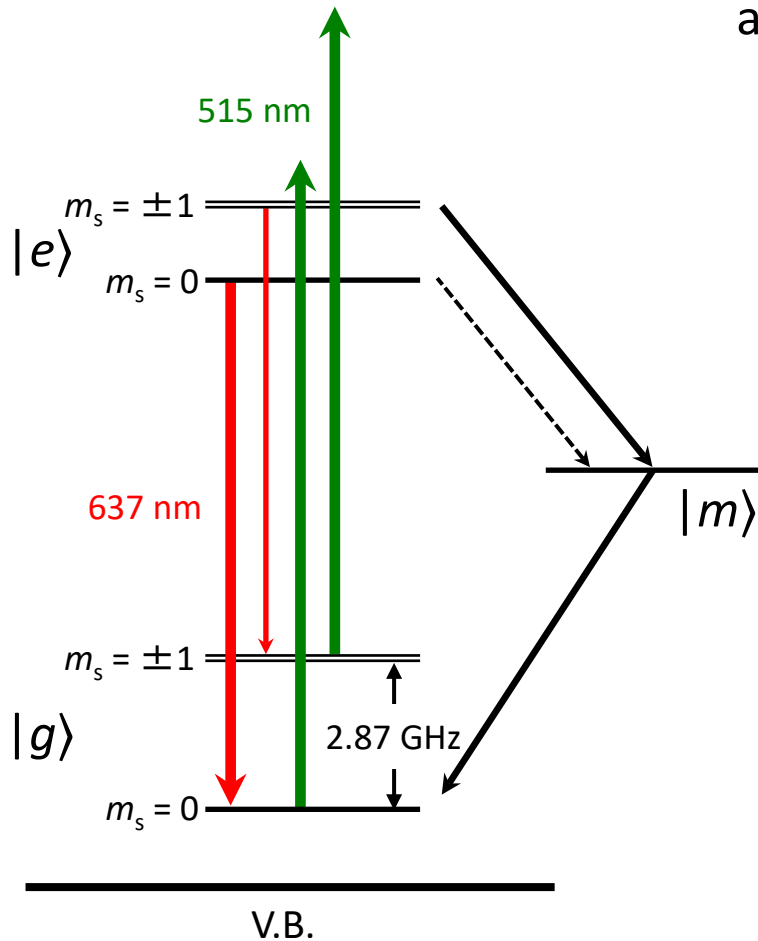

Optically detected magnetic resonance

C.B. ($E_g = 5.47 \text{ eV} = 227 \text{ nm}$)

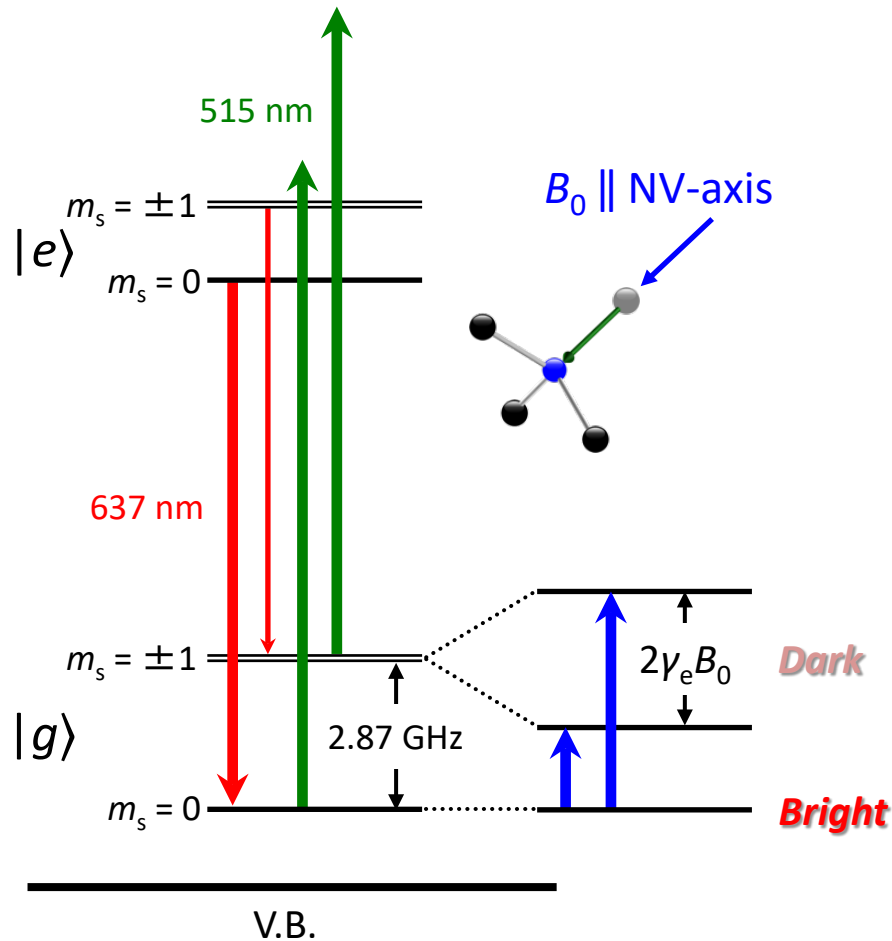

$$H = DS_Z^2 + \gamma_e B_0 S_Z$$

$$D = 2.87 \text{ GHz}, \gamma_e = 28 \text{ MHz/mT}$$

$$B_0 = 4.7 \text{ mT}, f_{\pm} = 2.87 \pm 0.132 \text{ GHz}$$

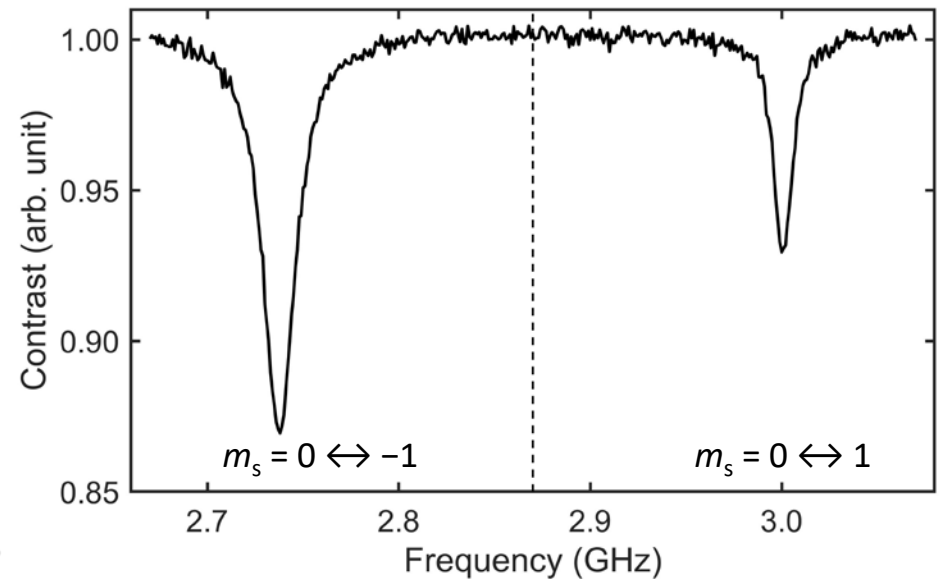

Experimental setup

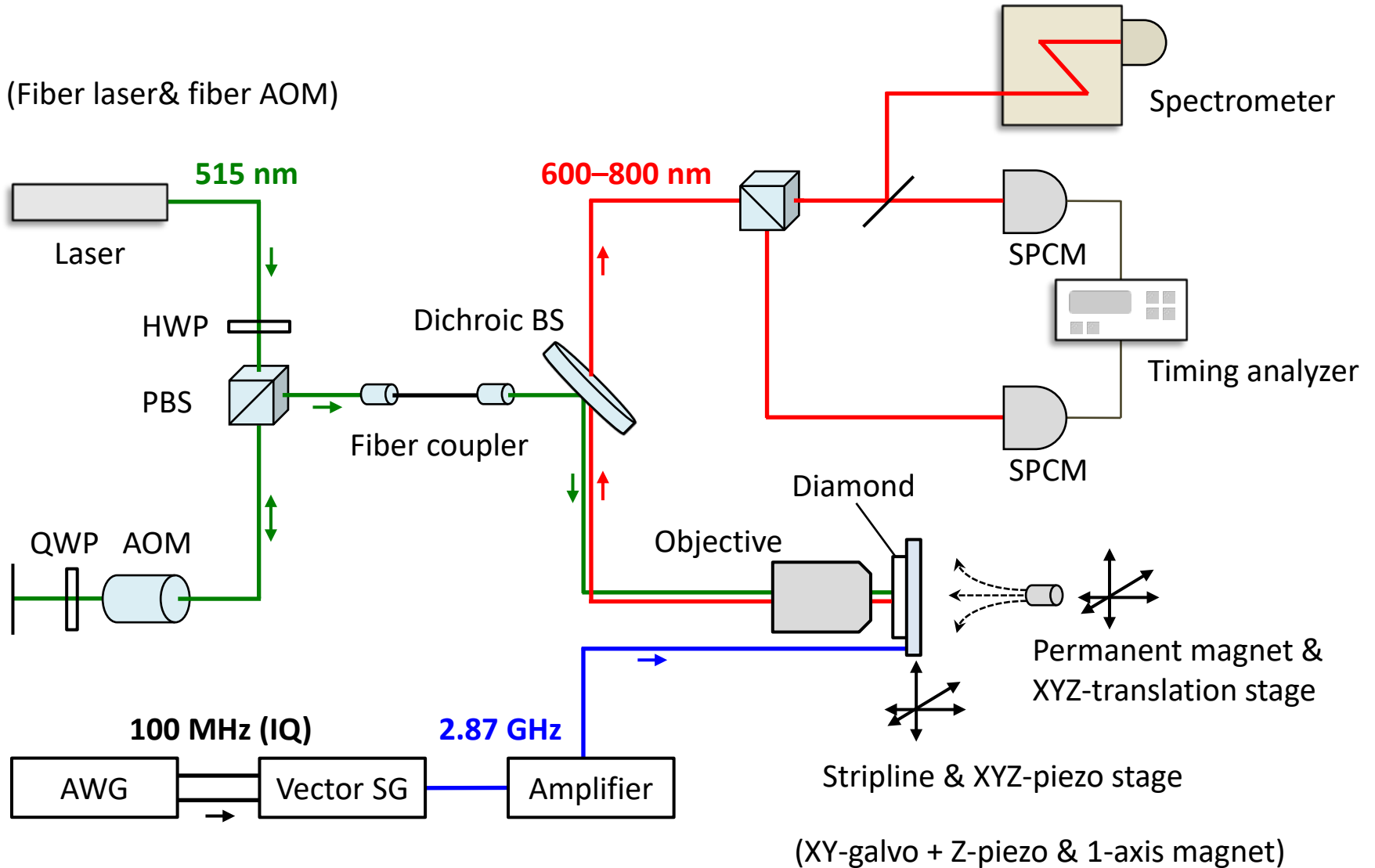

Experimental setup

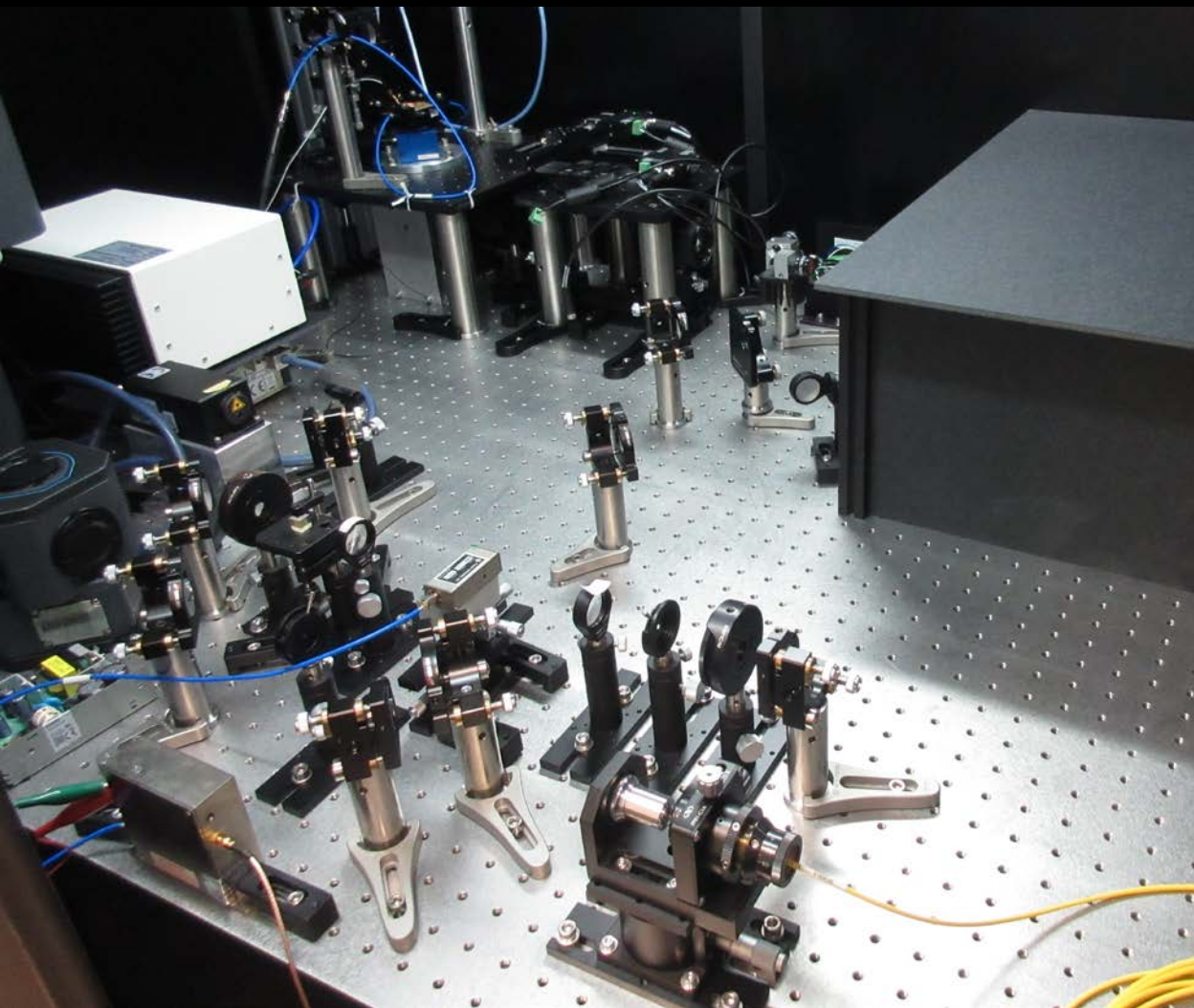

Experimental setup

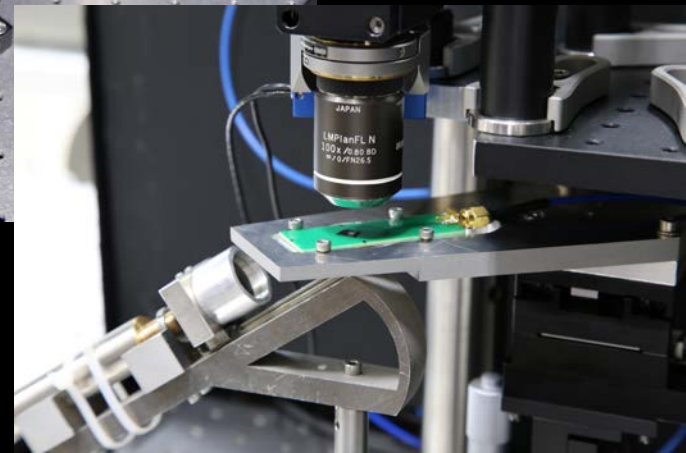
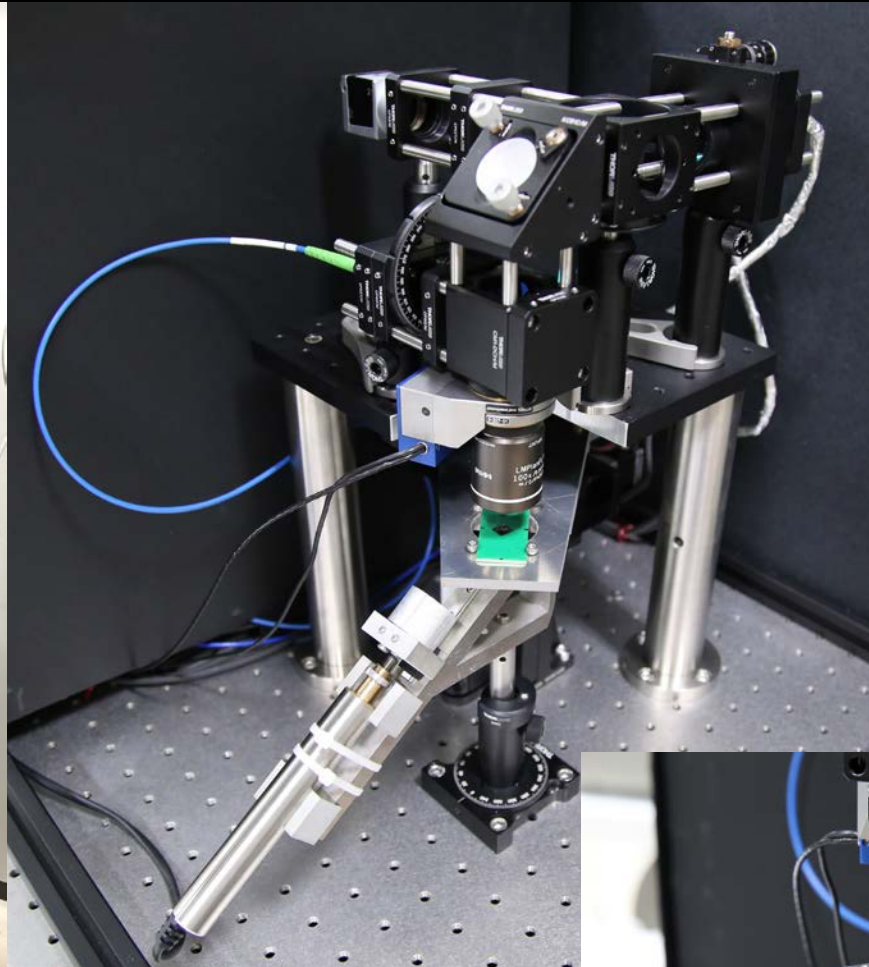

AIP Adv. **10**, 025206 (2020)
Misonou *et al.*

Outline

- **Basics of NV centers in diamond**
 - Structure
 - Optical & magnetic properties
- **Basics of magnetic resonance**
- **Quantum sensing**
 - AC magnetometry
 - Detection of proton spin ensemble
 - Detection and control of a single proton spin

Magnetic resonance

Torque equation (Larmor precession)

$$\frac{d\boldsymbol{\mu}}{dt} = \boldsymbol{\mu} \times \gamma \mathbf{B}_0$$

Gyromagnetic ratio

Magnetic moment: $\boldsymbol{\mu} = \gamma \mathbf{J}$

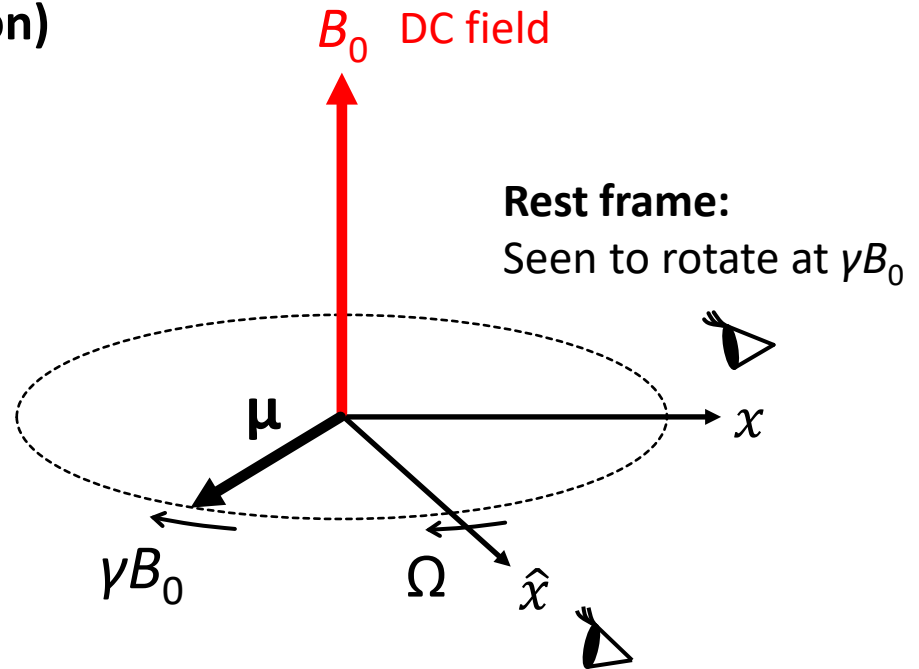

Frame rotating at angular velocity Ω :
Rotate slower...why?



Joseph Larmor
(1857–1942)

(from Wikipedia)

Magnetic resonance

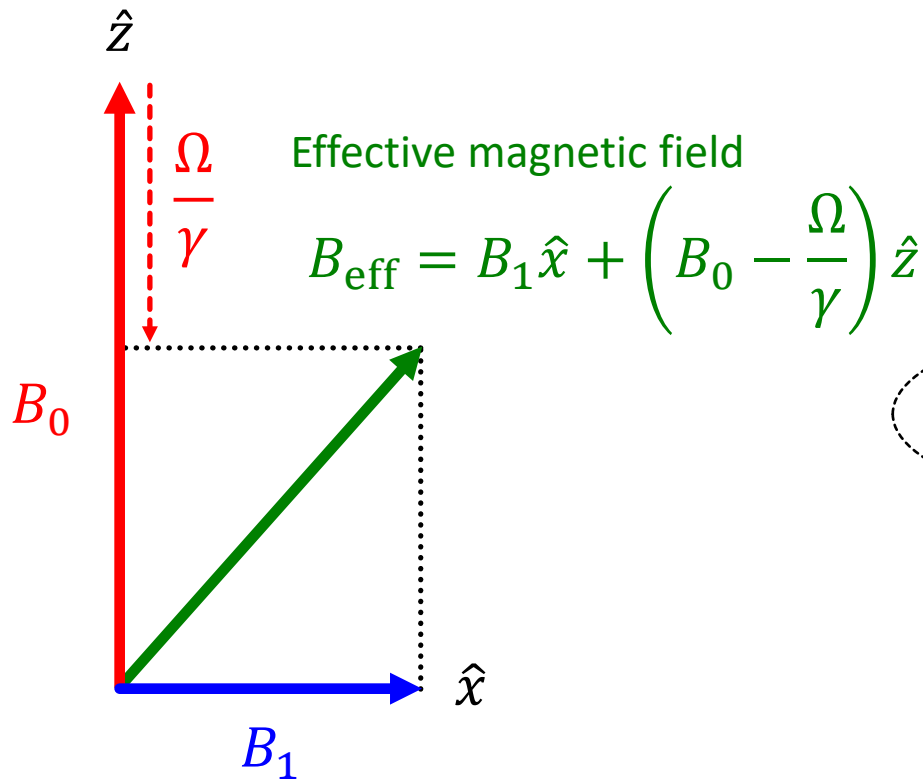

AC field rotating in the xy plane at Ω

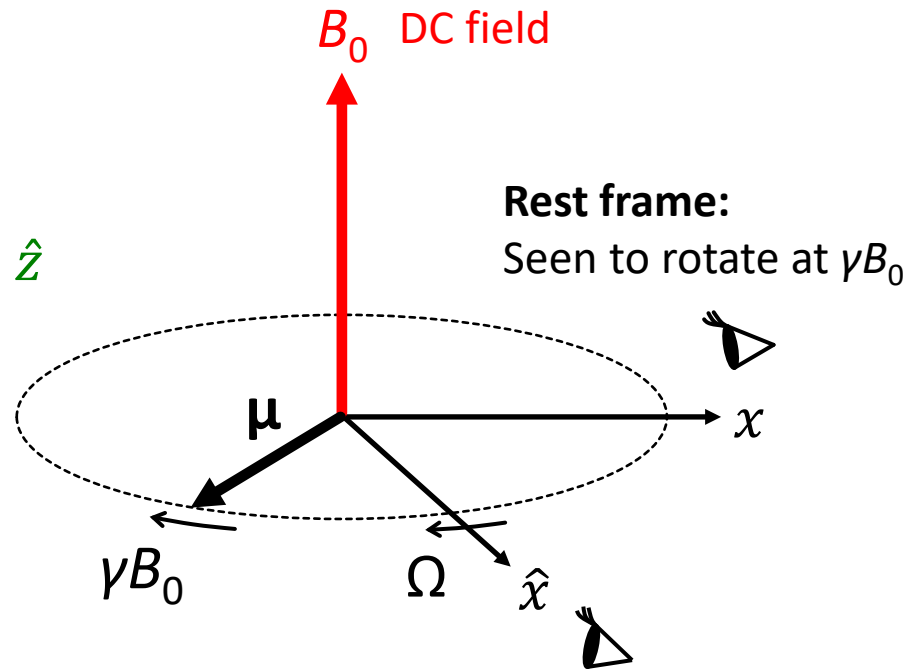

Frame rotating at angular velocity Ω :
Rotate slower...why?



DC field along the z direction becomes weaker

Magnetic resonance

Frame rotating at $\Omega = \gamma B_0$

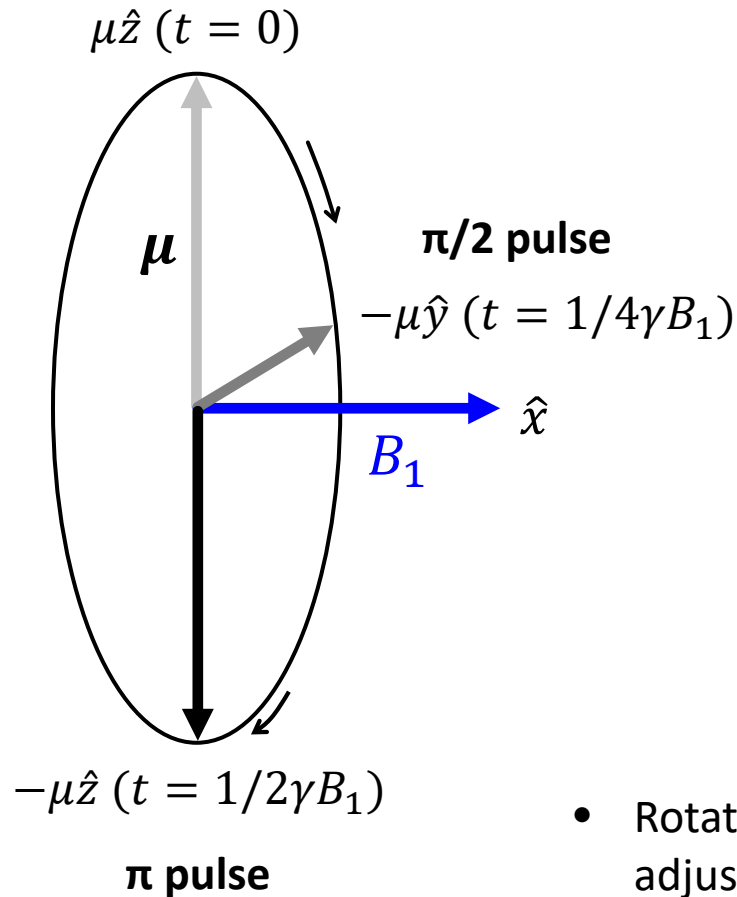

Rest (non-resonant) frame

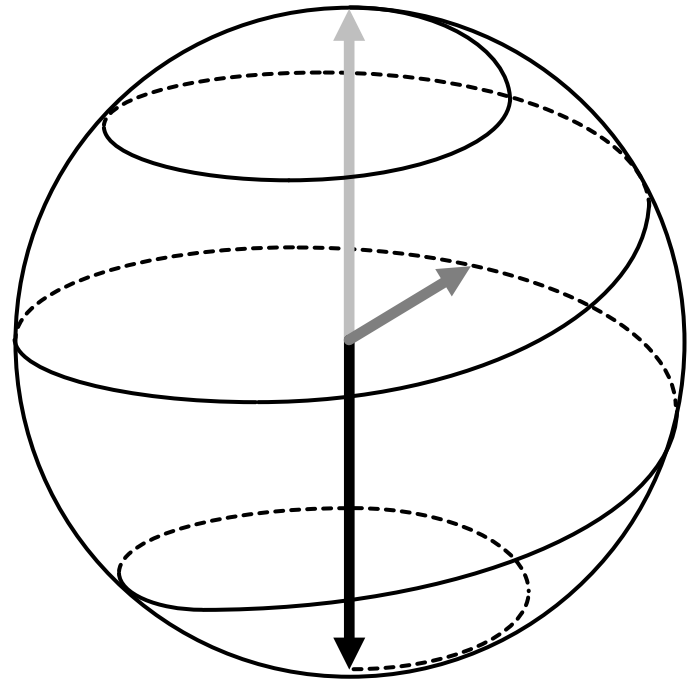

- Rotations about the $\pm \hat{x}, \pm \hat{y}$ axes are realized by adjusting the microwave phases
- Rotation about the \hat{z} axis is superposed when observed from the rest (non-resonant) frame

Qubit & Bloch sphere

Qubit, spin- $\frac{1}{2}$ (NV is spin-1!)

$$\begin{cases} |"0"> \equiv |m_s = 0> \\ |"1"> \equiv |m_s = -1> \end{cases}$$

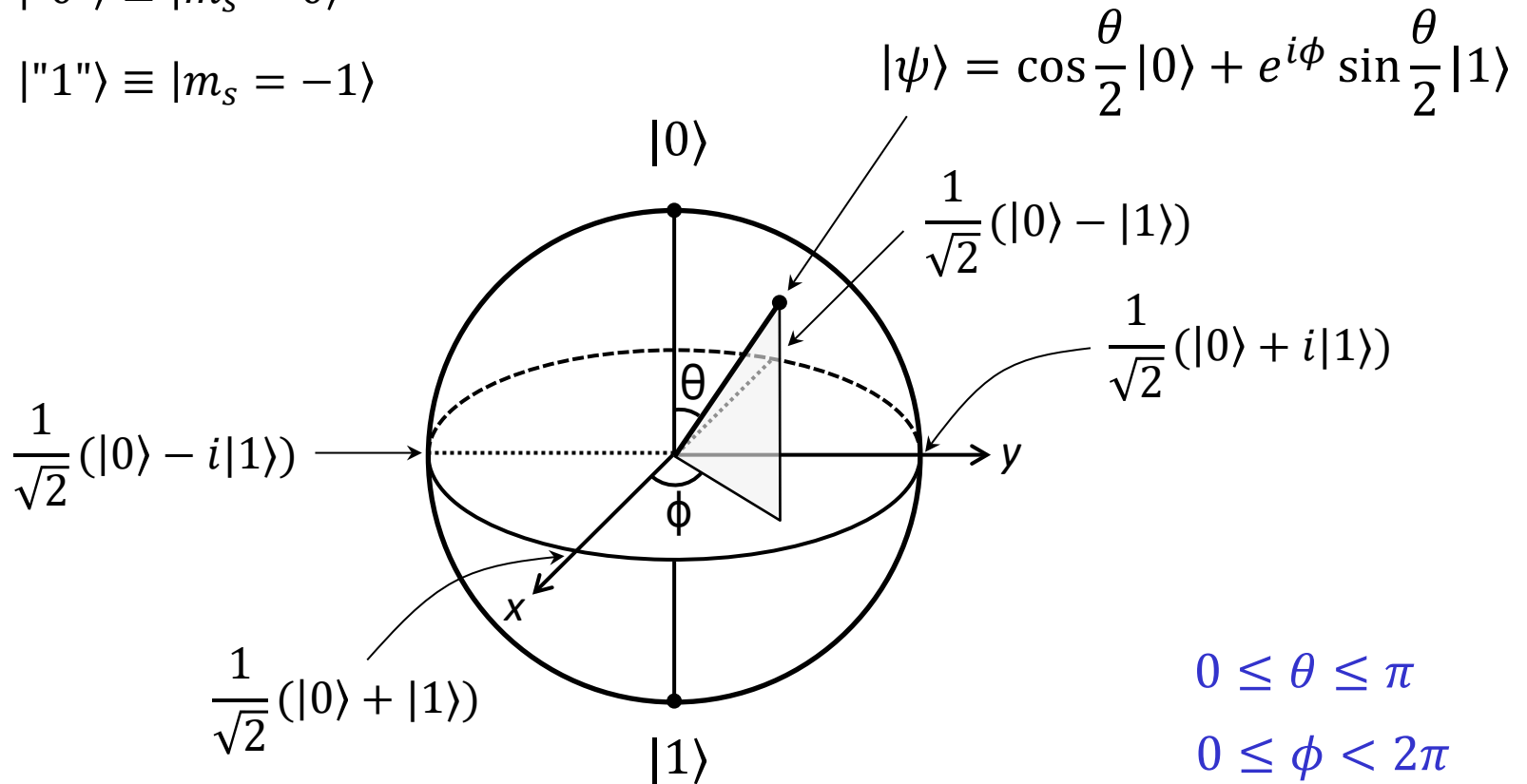

Rabi oscillation

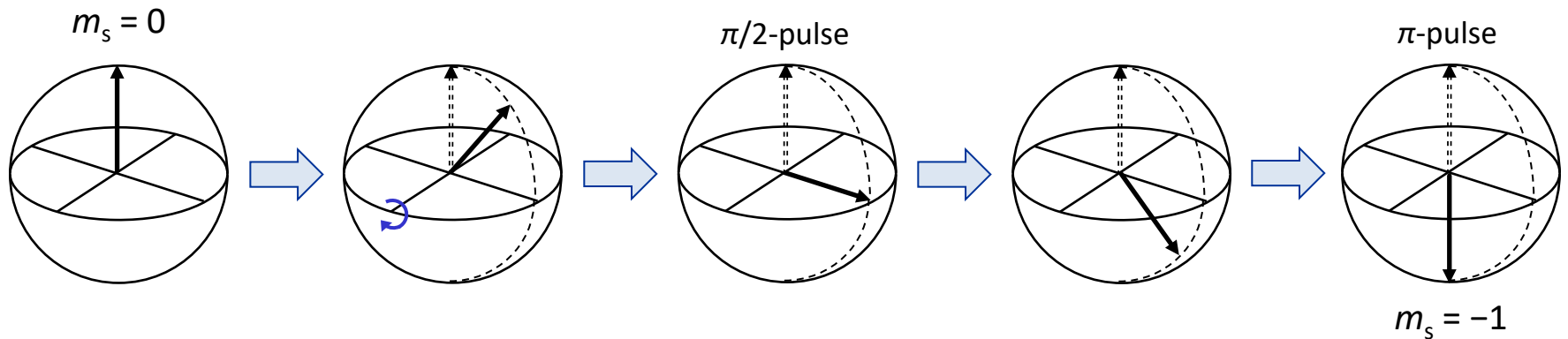
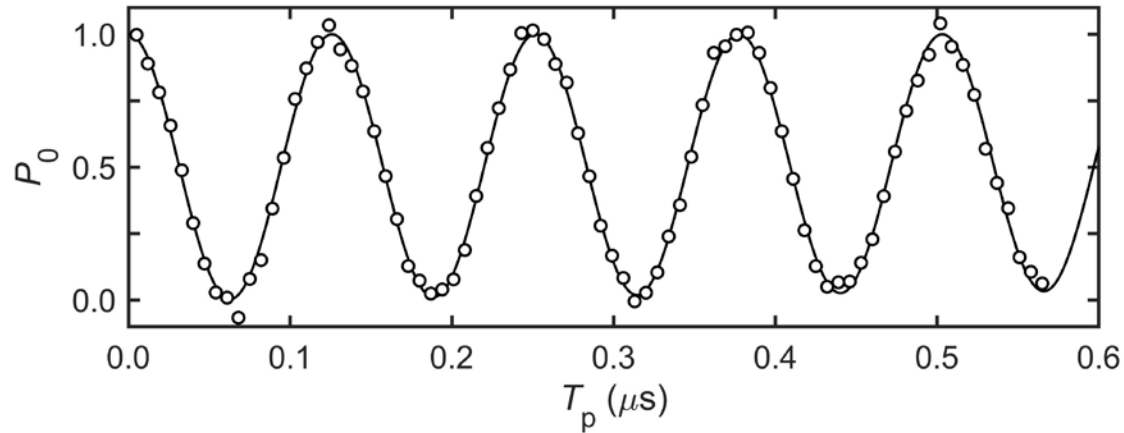
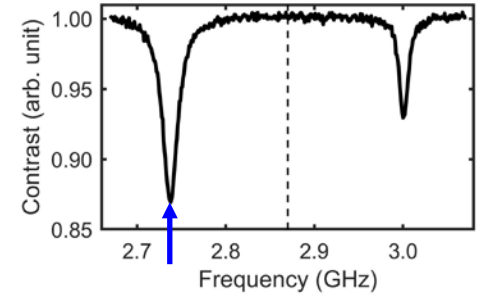
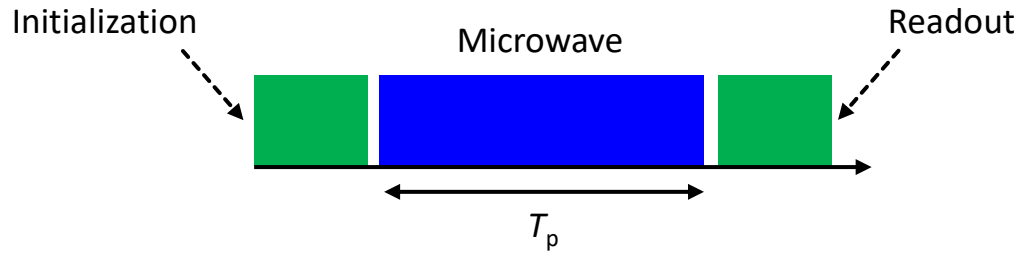

Quantum coherence

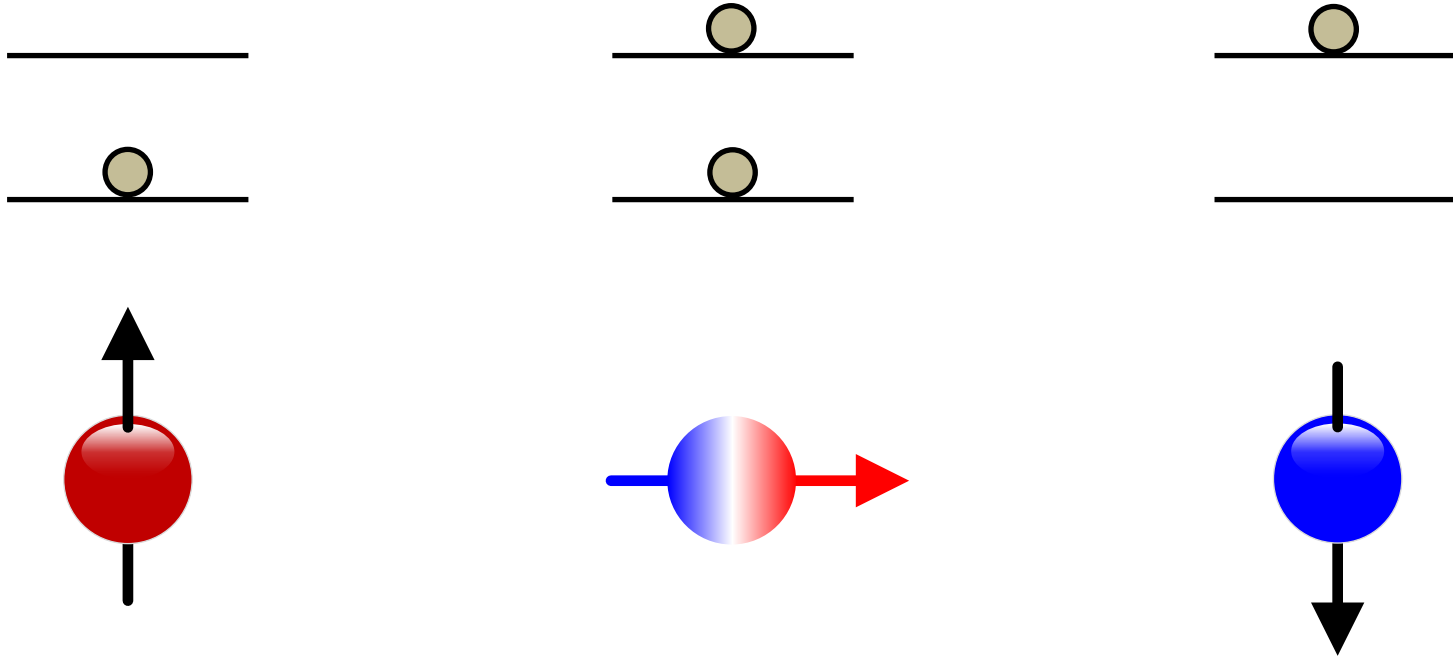

$$|0\rangle \equiv |m_s = 0\rangle$$

$$|\Psi\rangle = \alpha|0\rangle + \beta|1\rangle$$

$$|1\rangle \equiv |m_s = -1\rangle$$

T_2 : measure of how long a superposition state is preserved

Measurement of T_2

Time domain → Decay time constant T_2

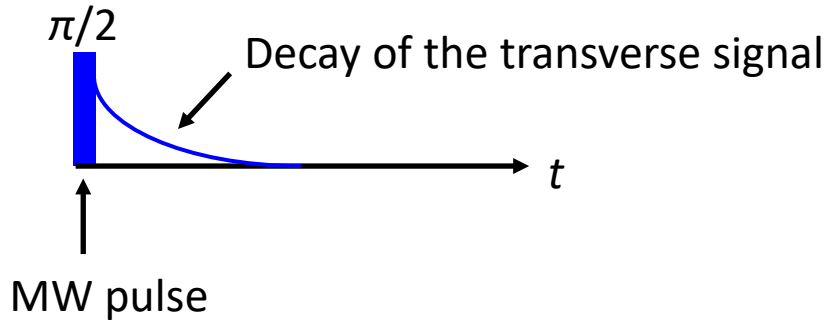

Frequency domain → Lorentz width

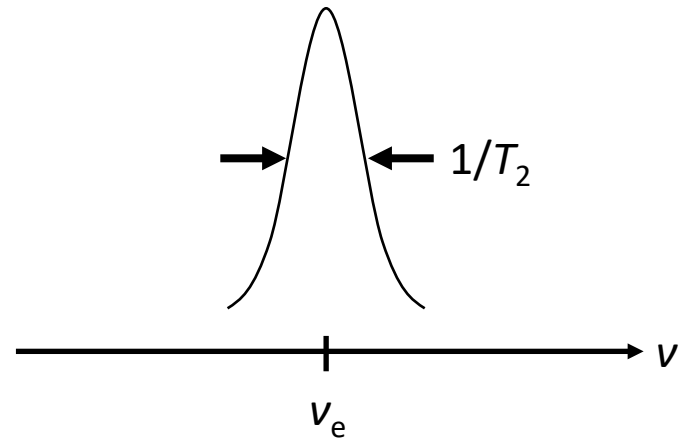

Measurement of T_2

Time domain \rightarrow Decay time constant T_2

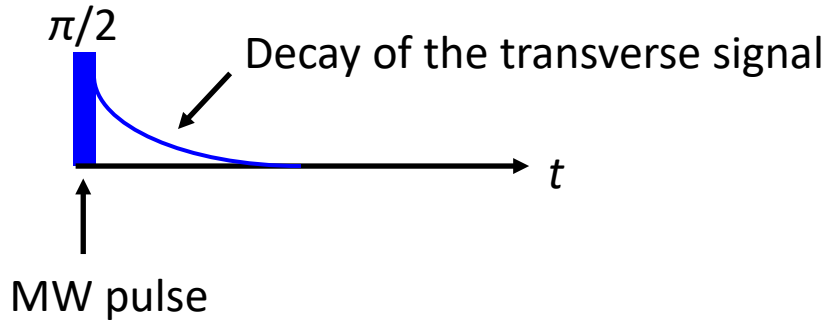

Frequency domain \rightarrow Lorentz width

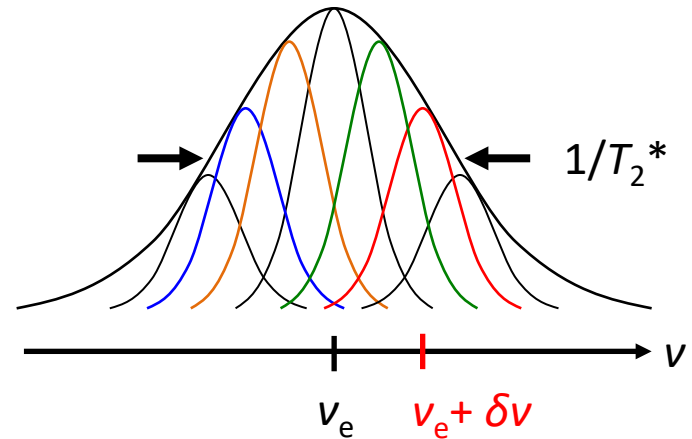

Inhomogeneous line broadening

Seen to precess at $\delta\nu$ in the frame rotating at ν_e

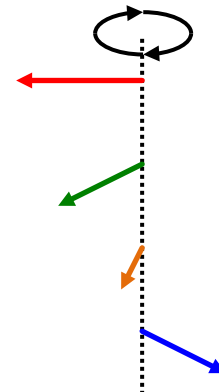
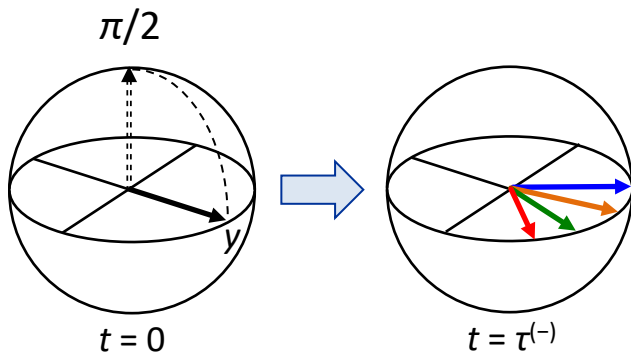

Spin echo

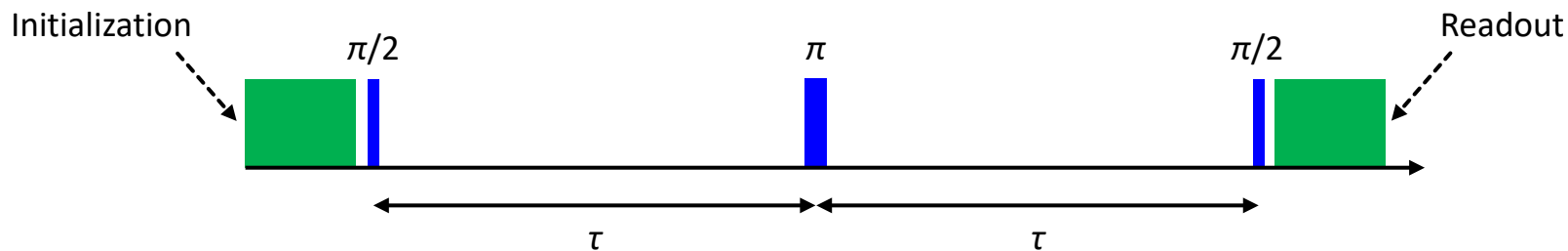

Modulation function

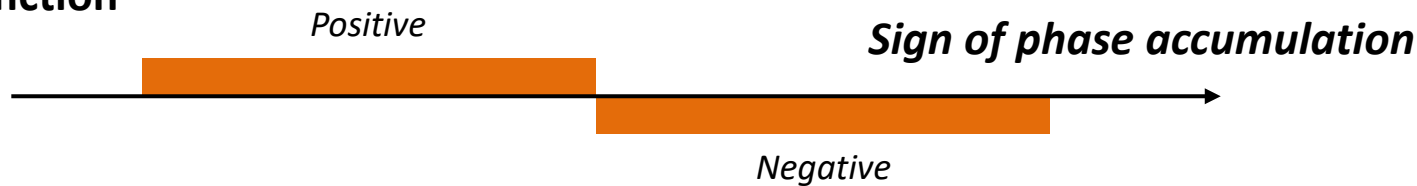

Phase accumulation by DC field (angle from the y axis)

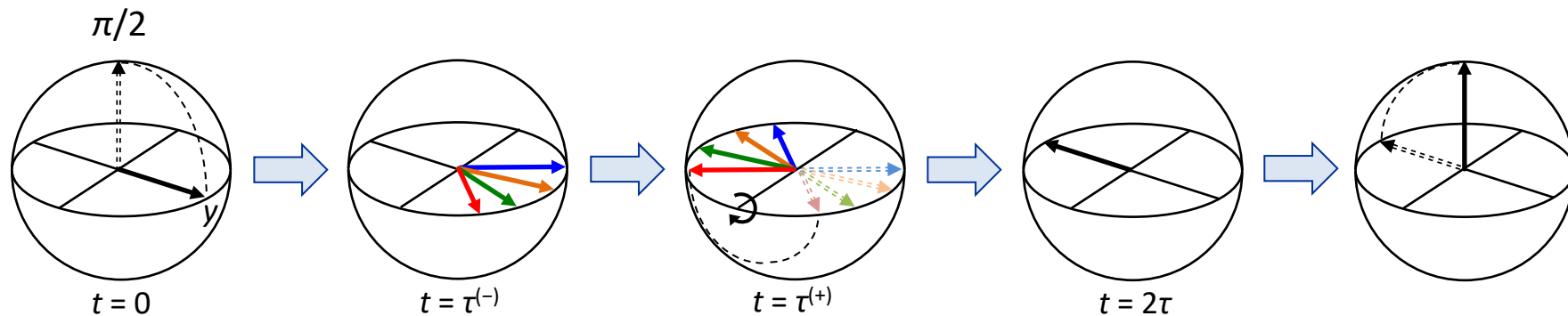
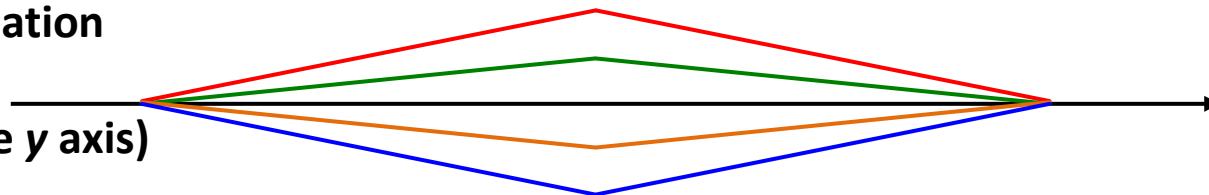

Coherence time

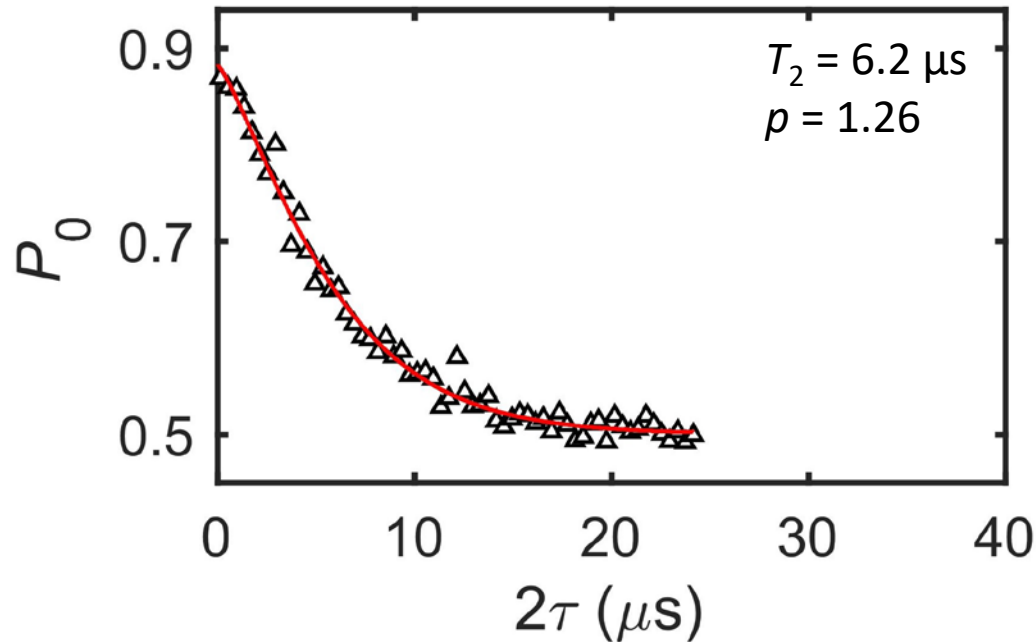

Stretched exponential decay

$$\exp\left[-\left(\frac{2\tau}{T_2}\right)^p\right]$$

Near-surface NV center

- N^+ implantation into ^{12}C ($l = 0$) layer
- $d_{\text{NV}} = 6.26 \text{ nm}$
- $B_0 = 23.5 \text{ mT}$

Outline

- **Basics of NV centers in diamond**
 - Structure
 - Optical & magnetic properties
- **Basics of magnetic resonance**
- **Quantum sensing**
 - AC magnetometry
 - Detection of proton spin ensemble
 - Detection and control of a single proton spin

Nuclear spin sensing

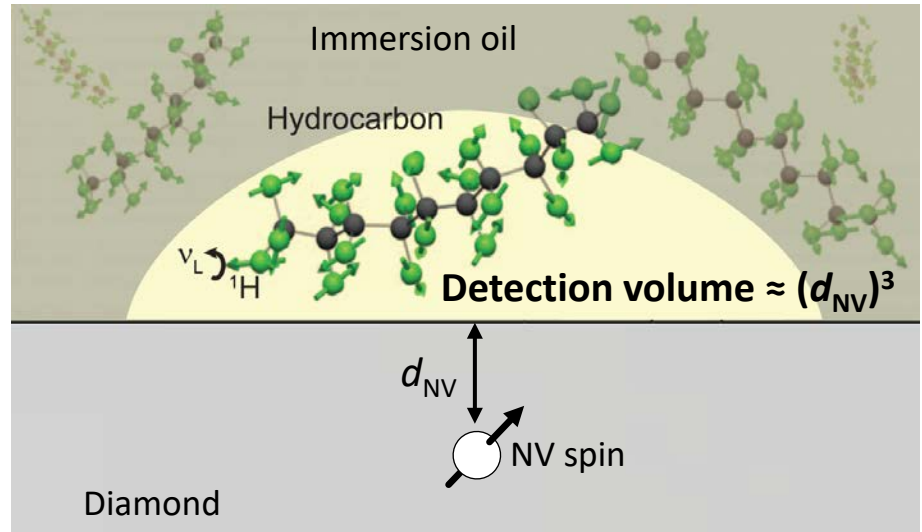
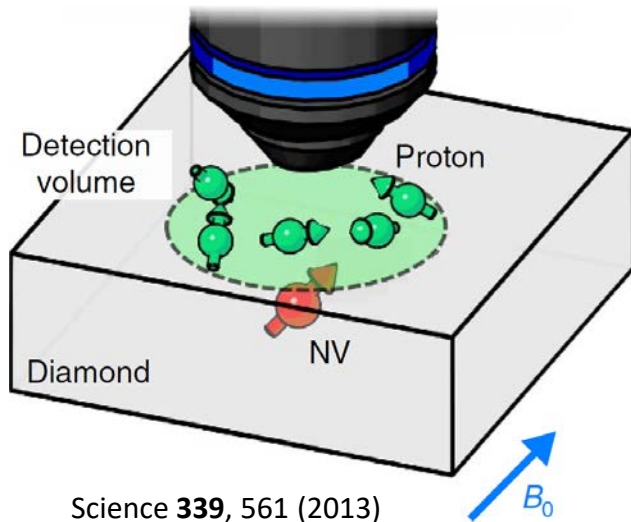

Nuclear spins **precess** at $f_{ac} =$ a few kHz–MHz under B_0



Weak AC magnetic field on the NV spin



Detect using **quantum coherence**

AC magnetometry

CP ($N = 4$)

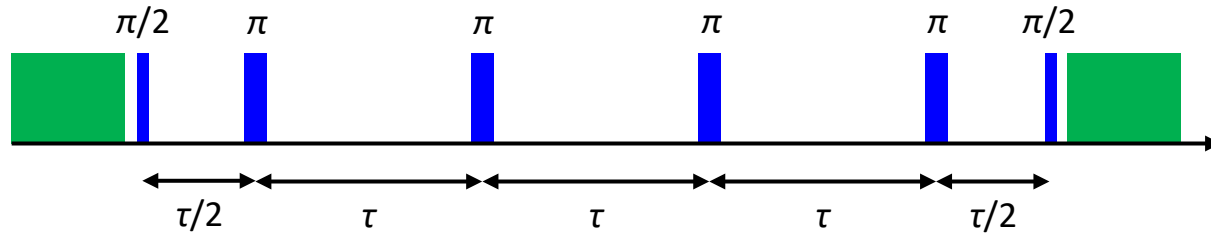

Modulation function



AC field at $f_{ac} = 1/2\tau$

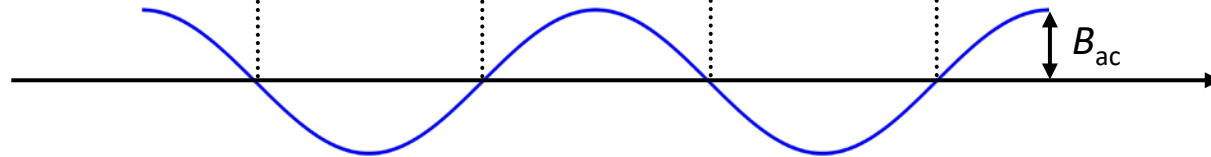

Sensor phase buildup = loss of coherence

$$\gamma B_{ac} \int_0^t |\cos(2\pi f_{ac} t)| dt$$

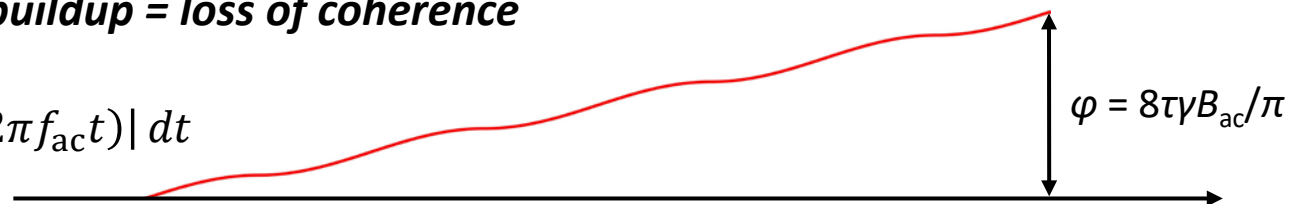

AC magnetometry

CP ($N = 4$)

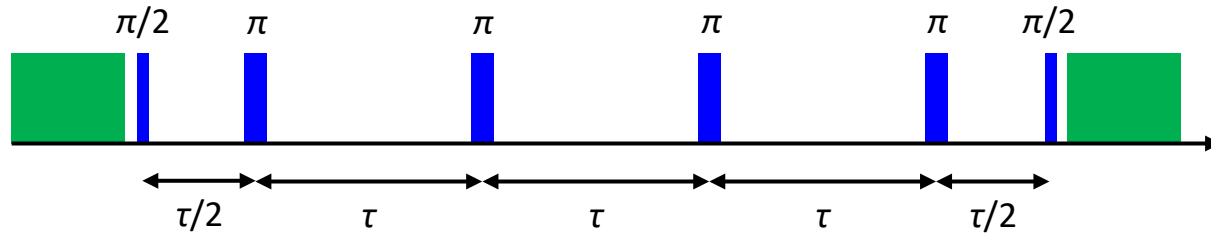

Modulation function

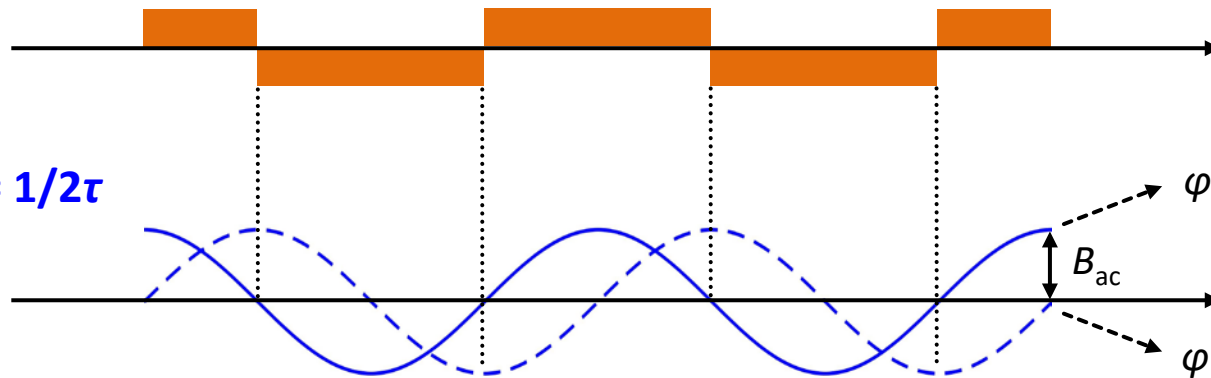

AC field at $f_{ac} = 1/2\tau$

- φ depends on the **initial phase α** of the AC field ($\varphi \propto \cos \alpha$)
- Average over **random α**

Nuclear spin sensing

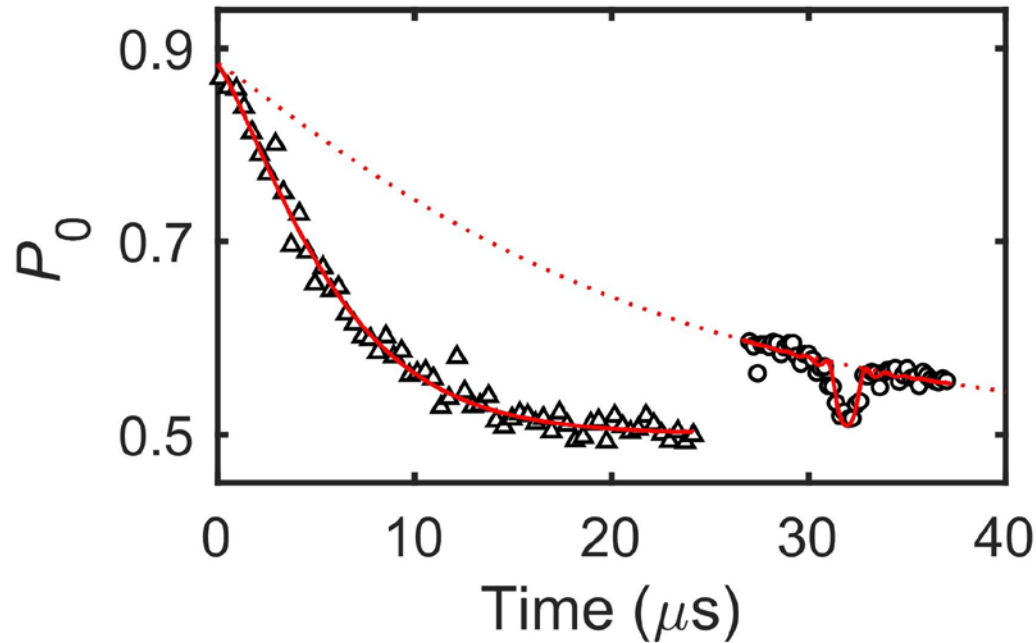

- $T_2 = 6.2 \mu\text{s} @ B_0 = 23.5 \text{ mT}$
- $N = 64$ (XY16)
- $2\tau = 2 \times 32 \mu\text{s} / 64 = 1 \mu\text{s}$
 $\rightarrow \gamma_{\text{H}} B_0 = (42.577 \text{ kHz/mT}) \times B_0 = 1.00 \text{ MHz}$

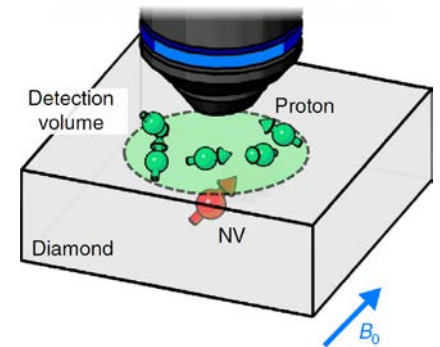

Nuclear spin sensing

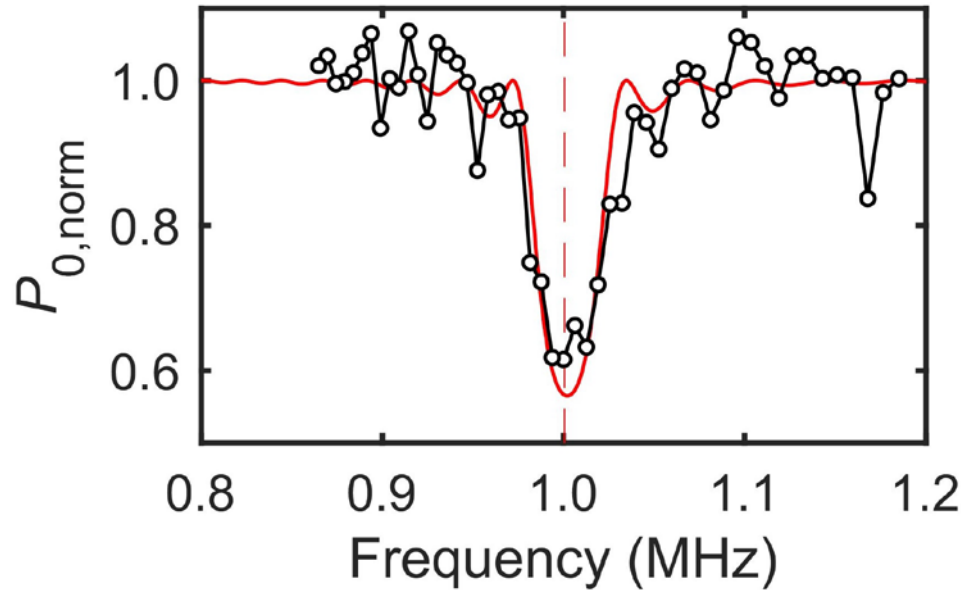

$$C(\tau) = f(B_{\text{rms}})$$

$$B_{\text{rms}} = \frac{\mu_0}{4\pi} h\gamma_{\text{H}} \sqrt{\frac{5\pi\rho}{96d_{\text{NV}}^3}}$$

Phys. Rev. B **93**, 045425 (2016)

- Proton density $\rho = 6 \times 10^{28} \text{ m}^{-3}$ (known)
- $d_{\text{NV}} = 6.26 \text{ nm}$
- $B_{\text{rms}} \approx 560 \text{ nT}$
- Detection volume $(d_{\text{NV}})^3 \approx 0.25 \text{ zL}$ (zepto = 10^{-21})
- # of proton $\rho(d_{\text{NV}})^3 \approx 1500$
- Thermal pol. (10^{-7}) vs. statistical pol. $(1500)^{0.5} \approx 39$

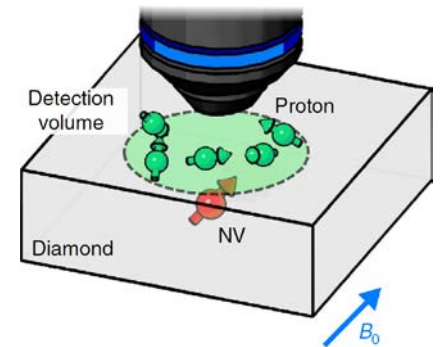

Toward single-molecular imaging

- **Strategy**
 - Detect **individual nuclear spins** in a single molecule
 - Determine their **nuclear species (& chemical shifts)** and **positions**
- **Practical issues**
 - Preparation of high-quality near-surface NV centers
 - Accurate positioning of single molecules/proteins near the sensor

Immobilized molecule

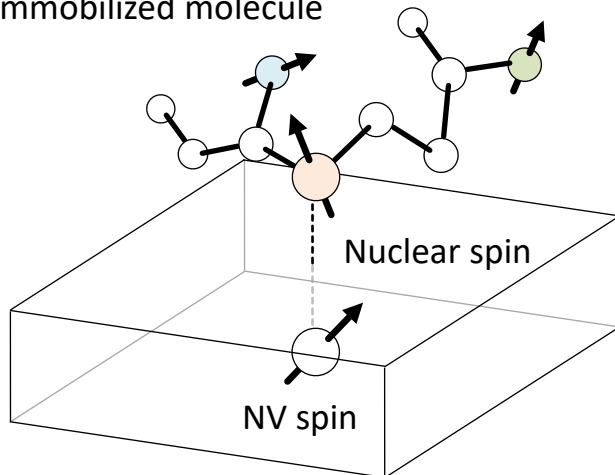

Detection of single protons in CVD diamond
(as a testbed)

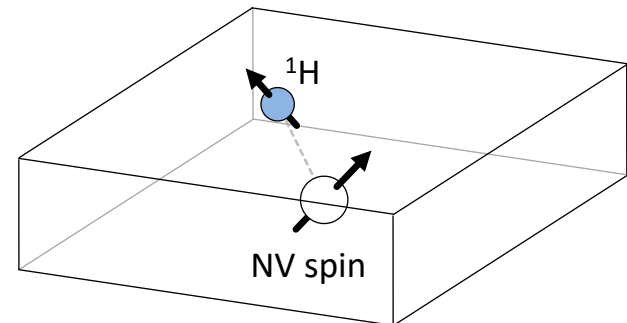

Nuclear spin sensing

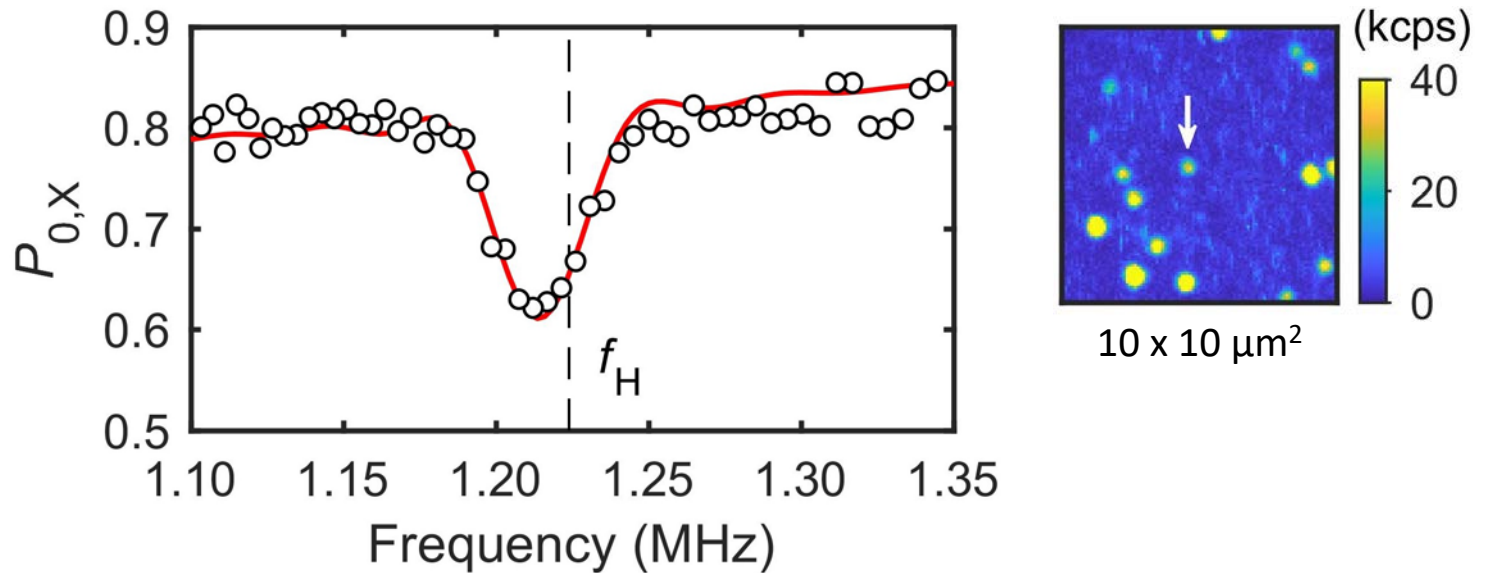

- Single NV in a N-doped CVD film ($[^{12}\text{C}] = 99.999\%$)
- $N = 64$ (XY16)
- $f_H = \gamma_H B_0 = 42.577 \text{ kHz/mT} \times 28.7 \text{ mT} = 1.2239 \text{ MHz}$

Correlation spectroscopy

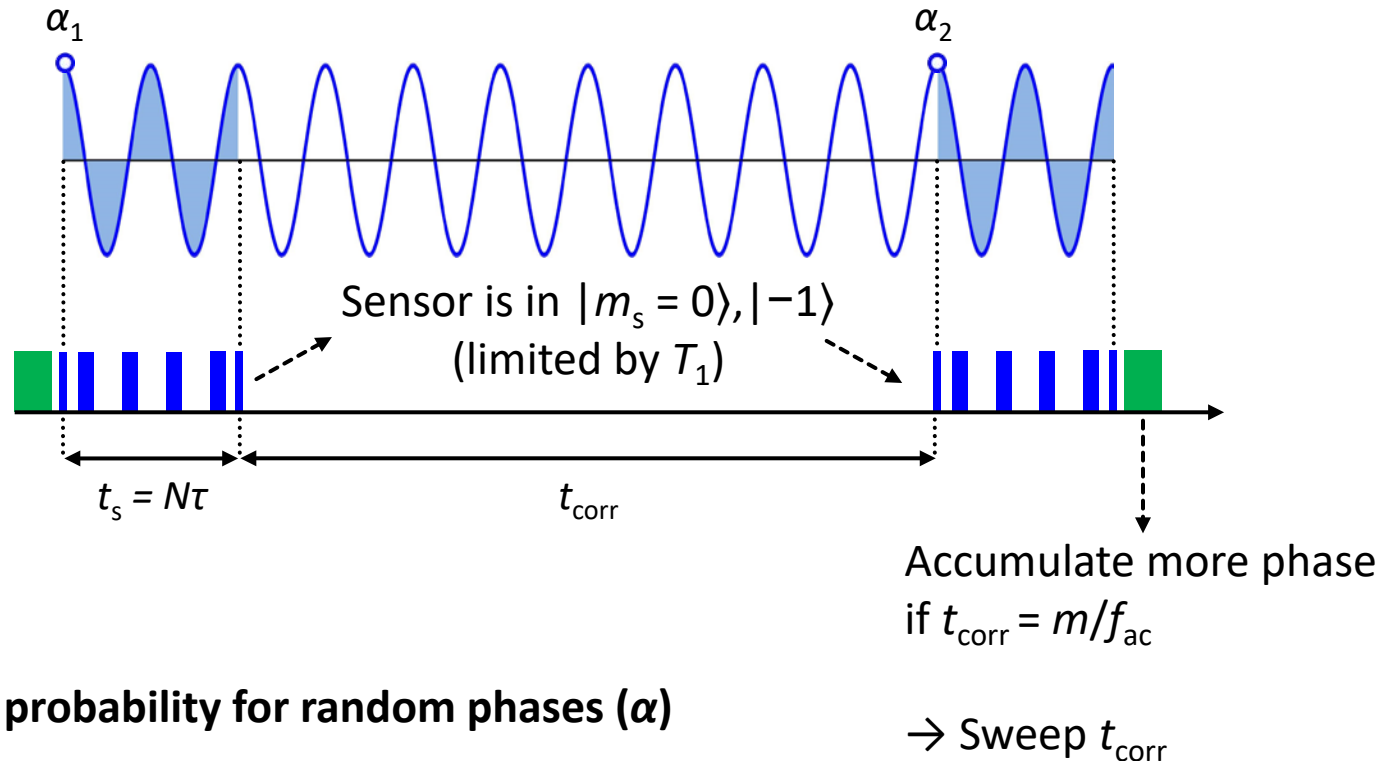

The transition probability for random phases (α)

$$p(t_1) \approx \frac{1}{2} \left\{ 1 - \frac{1}{2} \left(\frac{\gamma B_{\text{ac}} t_s}{\pi} \right)^2 \cos(2\pi f_{\text{ac}} t_{\text{corr}}) \right\}$$

- Nature Commun. **4**, 1651 (2013) Laraoui *et al.*
 Phys. Rev. Appl. **4**, 024004 (2015) Kong *et al.*
 Nature Commun. **6**, 8527 (2015) Staudacher *et al.*
 Phys. Rev. Lett. **116**, 197601 (2016) Boss *et al.*

Correlation spectroscopy of a nucleus

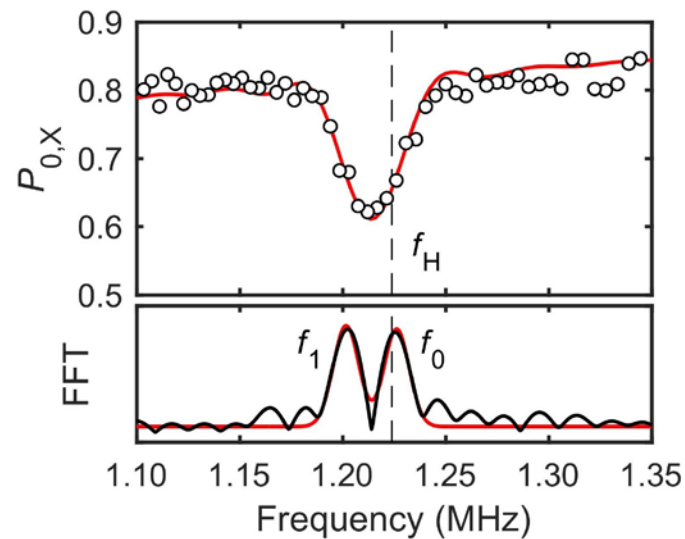
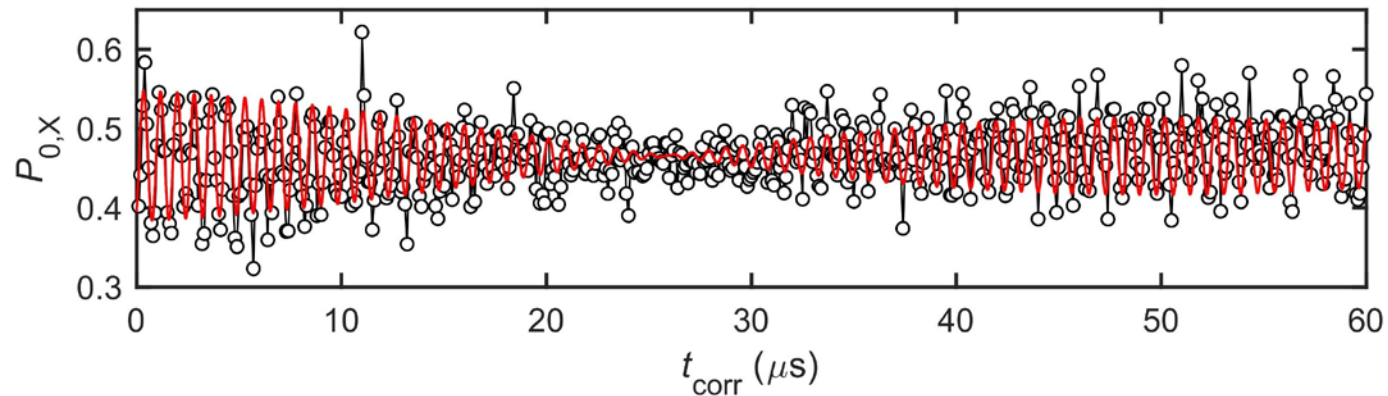

- $f_0 = 1.2234$ MHz
- $f_1 = 1.2046$ MHz

Correlation spectroscopy of a nucleus

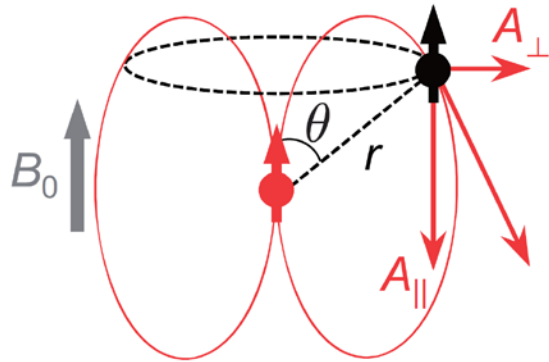

Hamiltonian of NV-¹H coupled system

$$H = f_H I_z + |m_s = -1\rangle\langle -1| (A_{\parallel} I_z + A_{\perp} I_x)$$

→ No hyperfine field when $|m_s = 0\rangle$

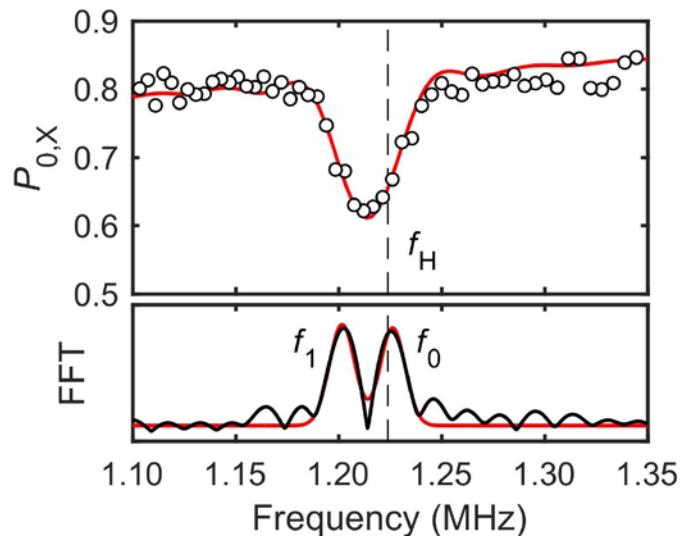

- $f_0 = 1.2234 \text{ MHz} = f_H (m_s = 0)$
- $f_1 = 1.2046 \text{ MHz} = f_H + A'_{\parallel} (m_s = -1)$

$$A'_{\parallel} = -18.8 \text{ kHz}$$

$$(f_0 + f_1)/2 = 1.2140 \text{ MHz} \rightarrow \text{dip}$$

Coherent control of a nuclear spin

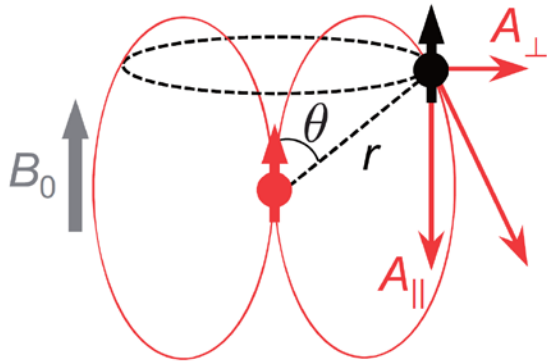

Hamiltonian of NV-¹H coupled system

$$H = f_{\text{H}} I_z + |m_s = -1\rangle\langle -1| (A_{\parallel} I_z + A_{\perp} I_x)$$

→ The single ¹H *n*-spin rotates about the A_{\perp} axis

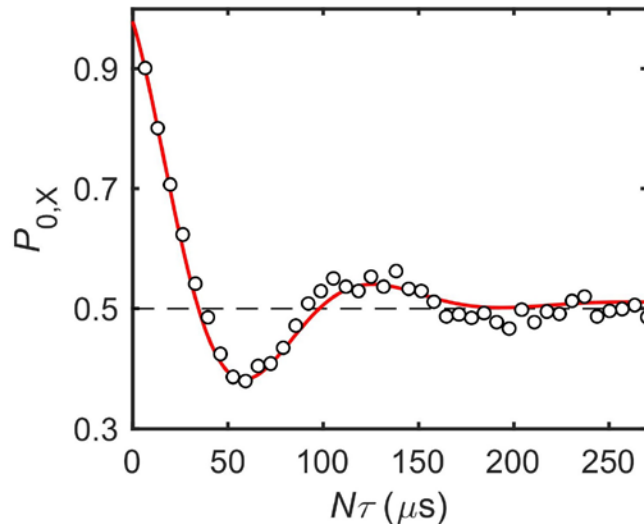

- $N \rightarrow 656$ ($\tau = 412.5$ ns, fixed)
- $f_{\text{osc}} = 7.414$ kHz = $A'_{\perp}/2$

Conditional rotation of a nuclear spin

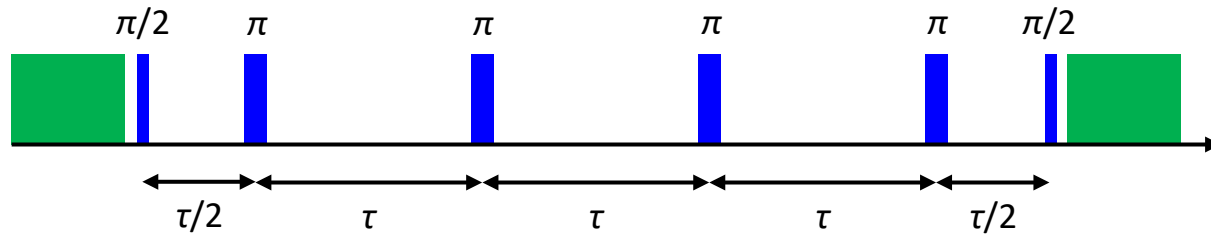

Evolution of n -spin vector

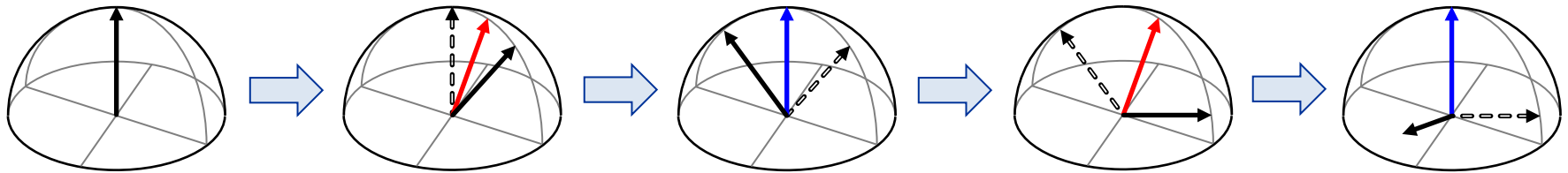

$|m_s = 0\rangle$
 $|m_s = -1\rangle$

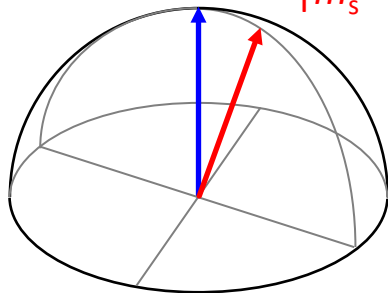

q-axis of n -spin

Start from $|m_s = 0\rangle$

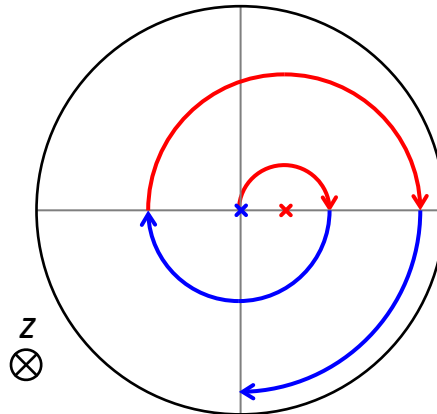

Start from $|m_s = -1\rangle$

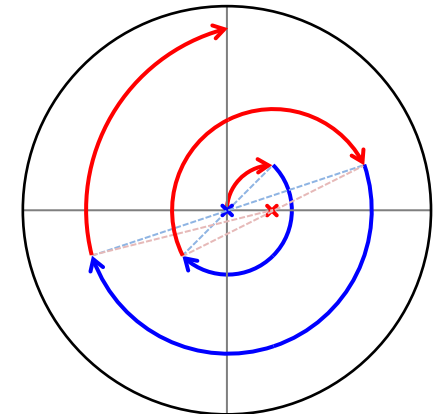

Coherent control of a nuclear spin

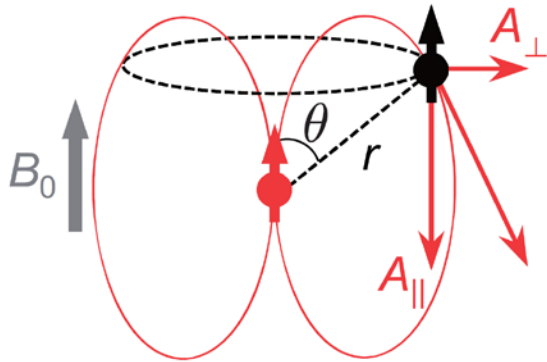

Transition probability of the NV spin

$$P_{0,X} = 1 - \frac{1}{2} (1 - \underbrace{\mathbf{n}_0 \cdot \mathbf{n}_{-1}}_{-1}) \sin^2 \frac{N\phi_{cp}}{2}$$

Phys. Rev. Lett. **109**, 137602 (2012) Taminiau *et al.*

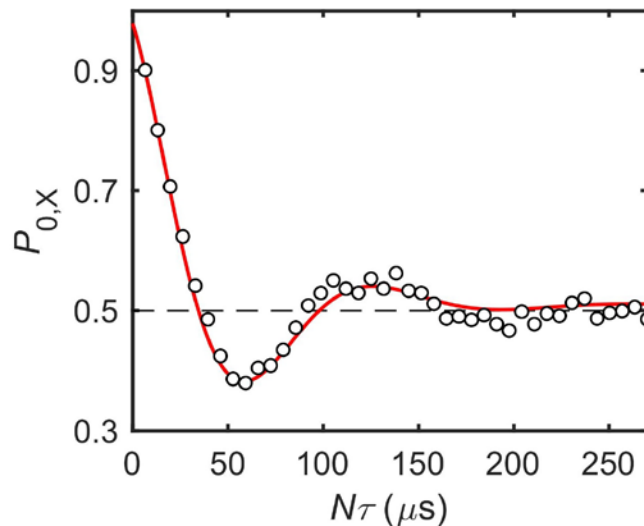

- $N \rightarrow 656$ ($\tau = 412.5$ ns, fixed)
- $f_{osc} = 7.414$ kHz = $A'_{\perp}/2$

$P_x < 0.5 \rightarrow$ Single proton!

Appl. Phys. Lett. **117**, 114002 (2020) Sasaki *et al.*

Determination of hyperfine constants

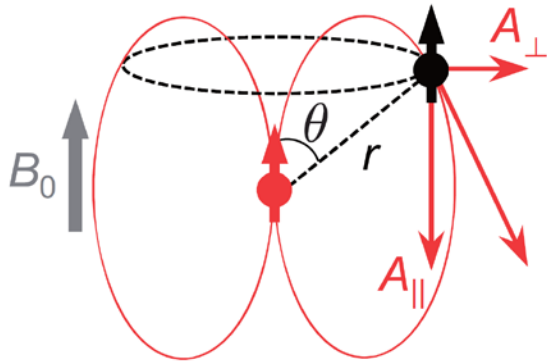

Magnetic dipole interaction

$$A_{\parallel} = h\gamma_e\gamma_H \frac{3 \cos^2 \theta - 1}{r^3}$$

$$A_{\perp} = h\gamma_e\gamma_H \frac{3 \cos \theta \sin \theta}{r^3}$$

$$\begin{aligned} A_{\parallel} &= -19.0 \text{ kHz} \\ A_{\perp} &= 22.9 \text{ kHz} \end{aligned}$$

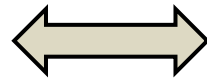

$$\begin{aligned} r &= 1.44 \text{ nm} \\ \theta &= 72.3^\circ \end{aligned}$$

The position of the nucleus can be determined
→ Molecular structure analysis

(Azimuthal angle ϕ) Phys. Rev. B **98**, 121405 (2018) Sasaki *et al.*

Appl. Phys. Lett. **117**, 114002 (2020) Sasaki *et al.*

Magnetic field dependence

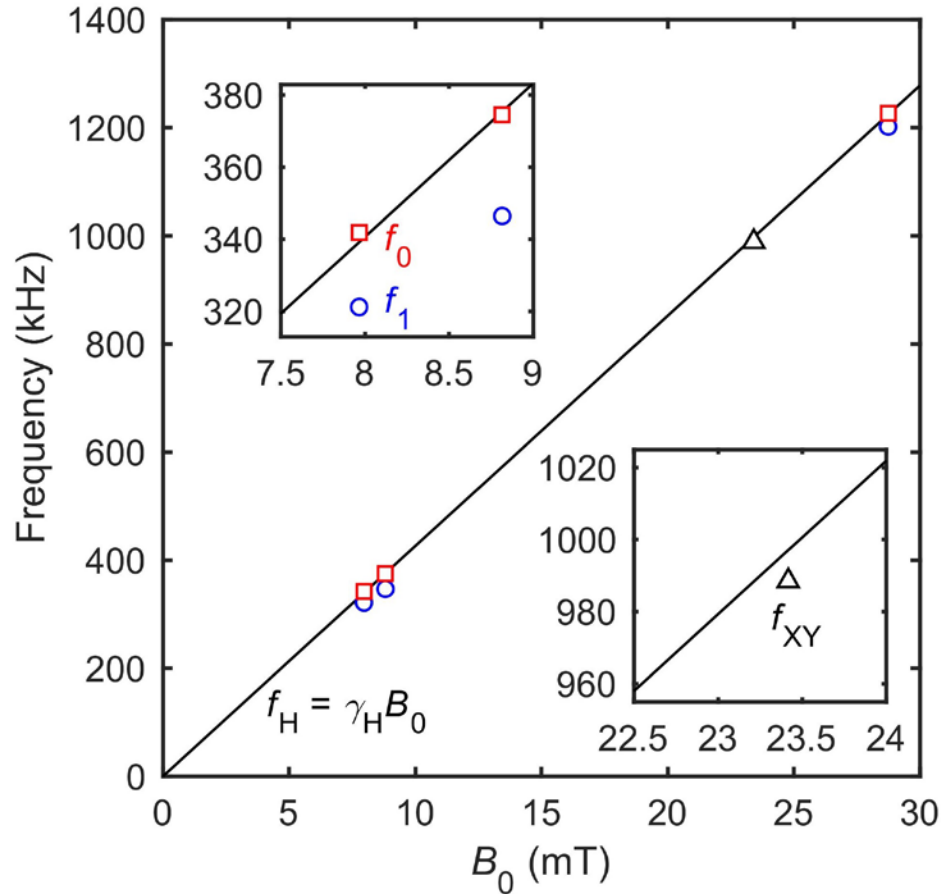

($\gamma_H/\gamma_C = 3.97 \rightarrow$ Spurious harmonics?) Phys. Rev. X 5, 021009 (2015) Loretz *et al.*

Appl. Phys. Lett. 117, 114002 (2020) Sasaki *et al.*

Toward single-molecular imaging

- **Spatial resolution**
 - Accurate measurement of $e-n$ int. const's (A_{\parallel}, A_{\perp}) $\approx (r, \theta)$
 - Information on the azimuthal angle ϕ
- **Spectral resolution**
 - Nuclear species
 - J -couplings & chemical shifts (ppm!)
 - Limited by sensor/memory lifetimes ($T_{2e/n}, T_{1e/n}$)

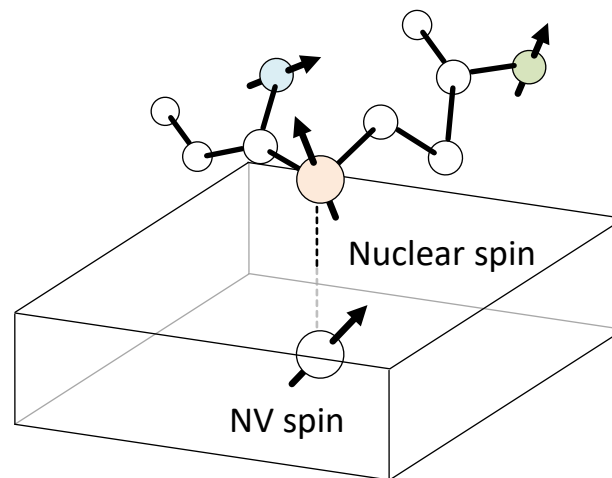

AC magnetometry revisited

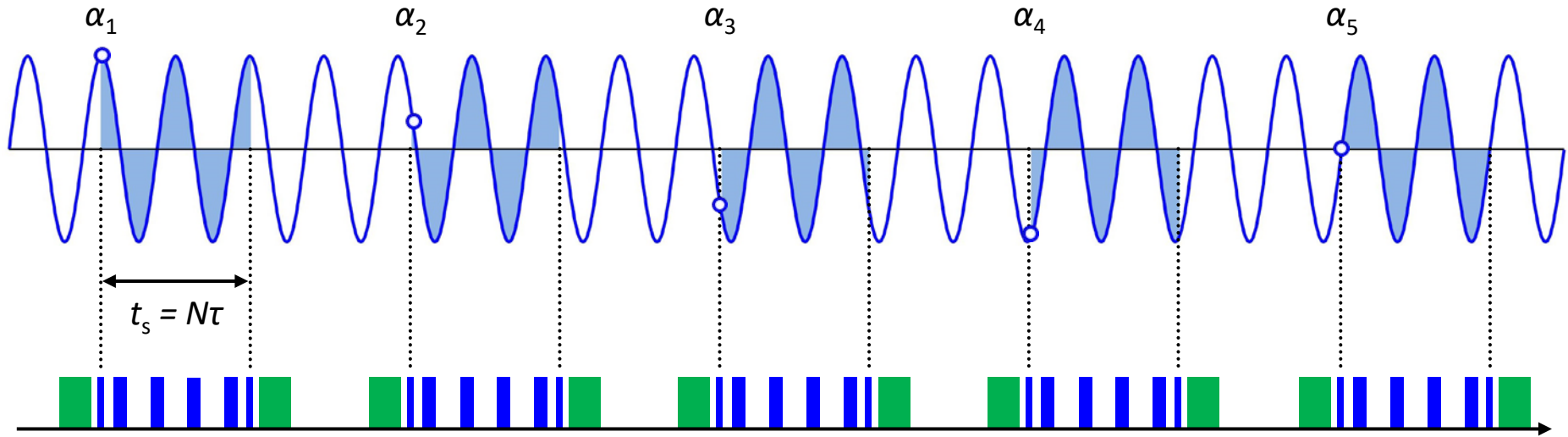

- φ depends on the **initial phase α** of the AC field ($\varphi \propto \cos \alpha$)
- Average over **random α**

Ultrahigh resolution sensing

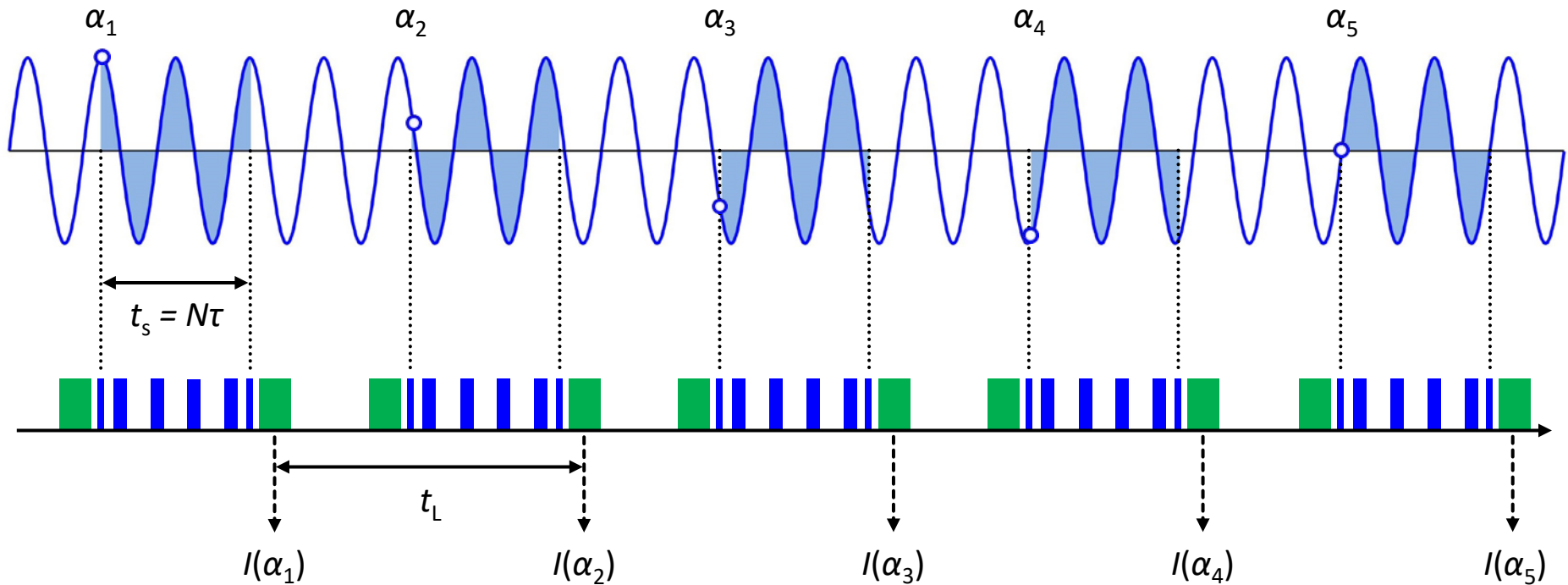

- φ depends on the **initial phase α of the AC field** ($\varphi \propto \cos \alpha$)
- Average over **random α**
- **If the data acq. is periodic**, adjacent α 's are related by $\alpha_{k+1} = 2\pi f_{ac} t_L + \alpha_k$

Ultrahigh resolution sensing

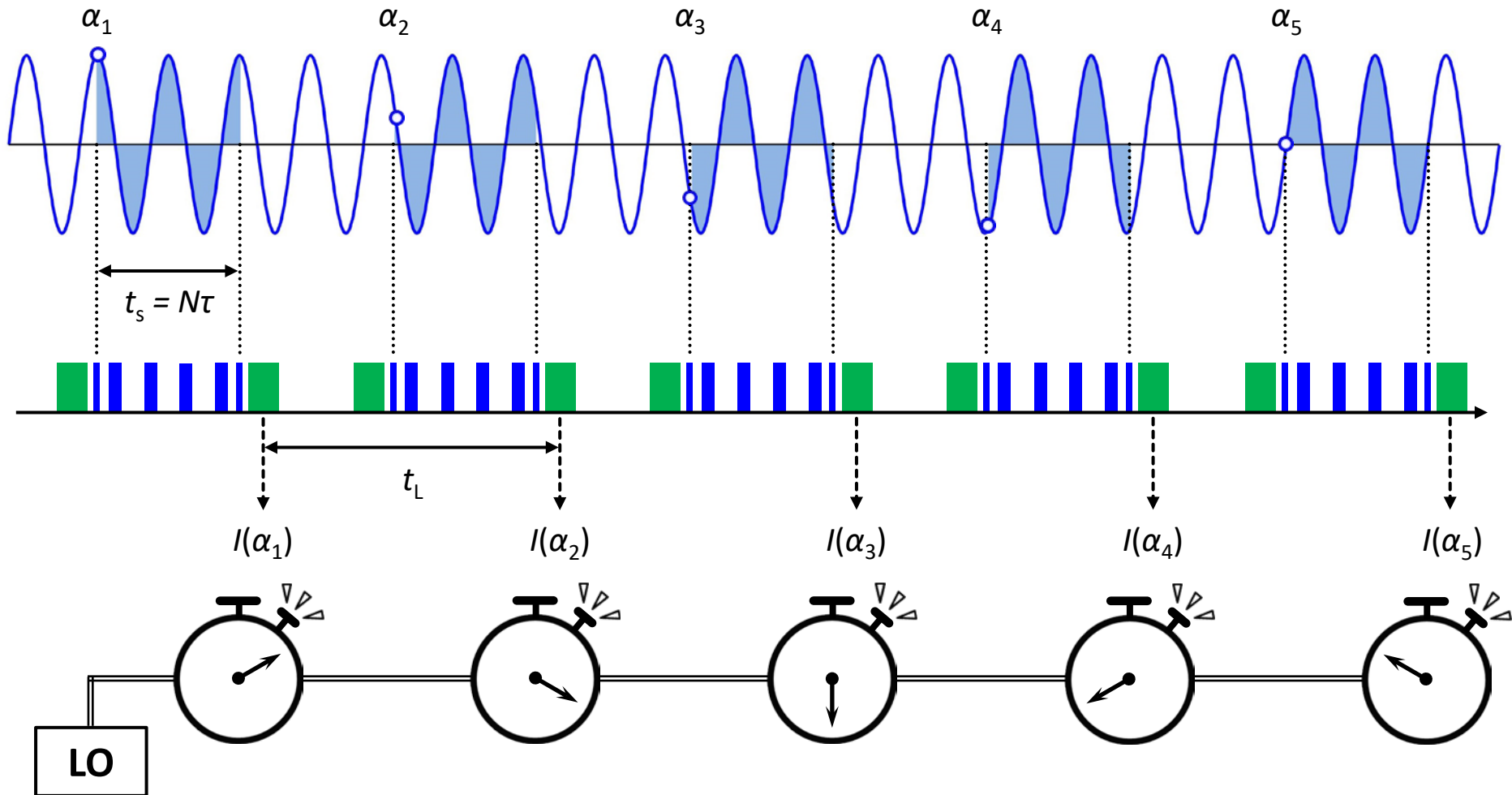

Undersampled, sensor-lifetime-unlimited signal

Ultrahigh resolution sensing

$B_{ac} = 96.5$ nT & $f_{ac} = 2.001$ MHz applied from a coil, detected by a single NV center

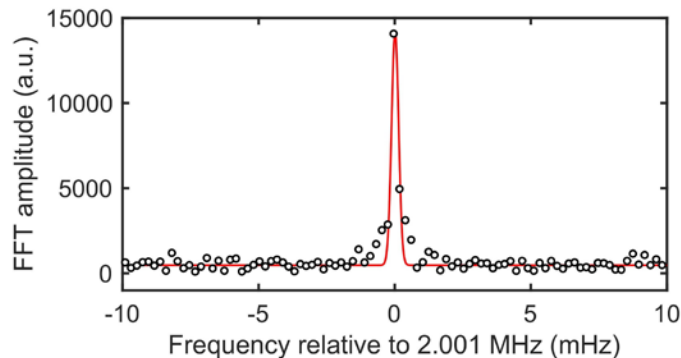
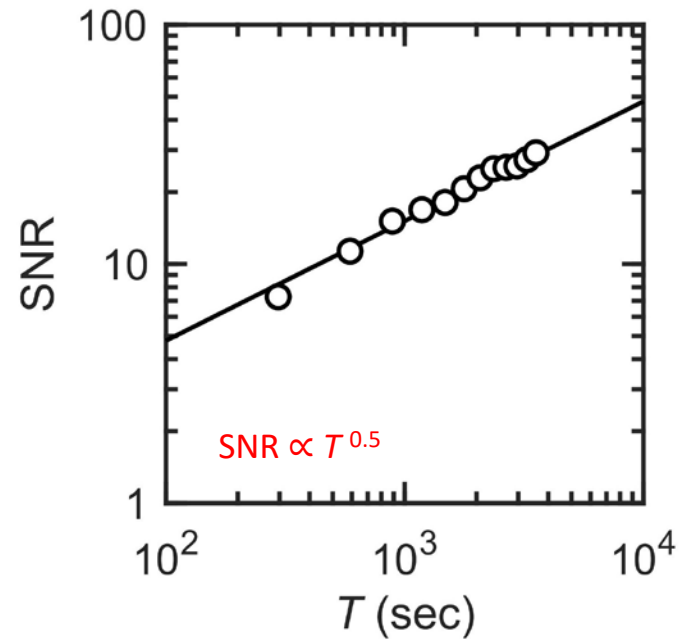
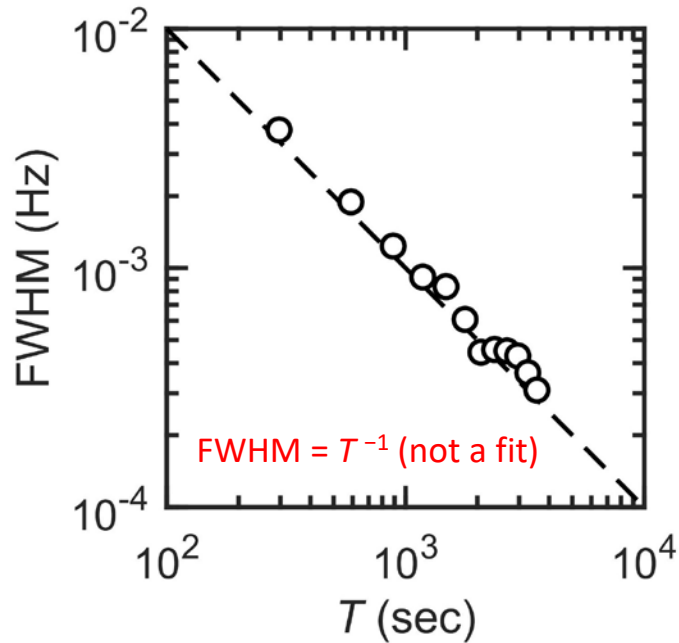

- $T = 3600$ sec
- FWHM = 0.304 mHz

Free induction decay

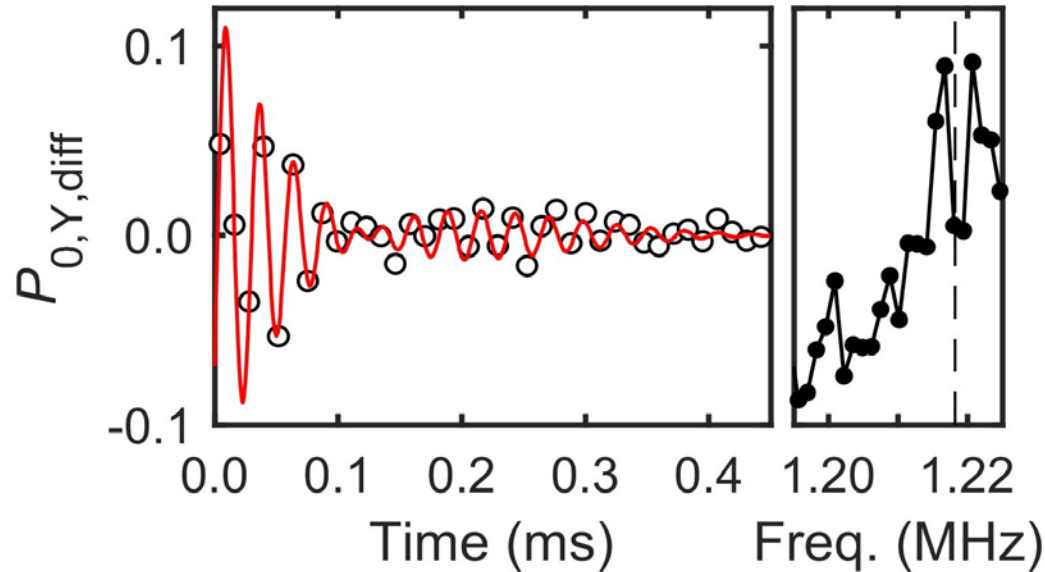

Nuclear Rabi oscillation

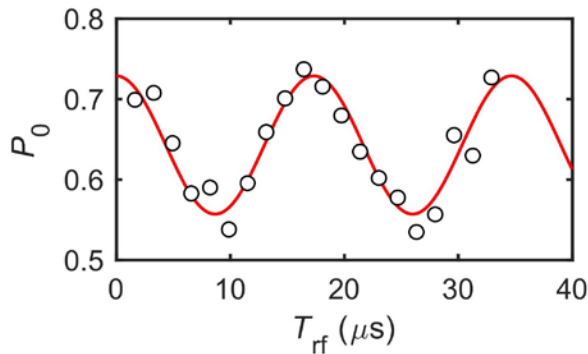

- $T_{rf, \pi/2} = 4.115 \mu s$
- $[PulsePol]-T_{rf, \pi/2}-[X/2-(XY16)-Y/2-L_{RO}]^{50}$
- $f_{sample} = 1/t_L = 84.46 \text{ kHz}$
- $f_p = (f_0+f_1)(t_s/t_L)/2+f_0(t_s-t_L)/t_L = 1.2182 \text{ MHz}$
 → Split (analogous to chemical shifts)

Summary

- **Tools for single-molecule imaging/structural analysis are being developed**
 - Ultrahigh resolution sensing^[1,2,3], resolving chemical shifts^[3,4] & suppression of back action from n -spins^[5,6]
 - Determination of the position of individual n -spins^[7,8,9]
 - Detection and control of single proton spins^[10,11]

[1] Science **356**, 832 (2017) Schmitt *et al.* (Ulm)

[2] Science **356**, 837 (2017) Boss *et al.* (ETH)

[3] Nature **555**, 351 (2018) Glenn *et al.* (Harvard)

[4] Science **357**, 67 (2017) Aslam *et al.* (Stuttgart)

[5] Nature Commun. **10**, 594 (2019) Pfender *et al.* (Stuttgart)

[6] Nature **571**, 230 (2019) Cujia *et al.* (ETH)

[7] Phys. Rev. B **98**, 121405 (2018) Sasaki *et al.* (Keio)

[8] Phys. Rev. Lett. **121**, 170801 (2018) Zopes *et al.* (ETH)

[9] Nature **576**, 411 (2019) Abobeih *et al.* (Delft)

[10] Phys. Rev. Lett. **113**, 197601 (2014) Sushkov *et al.* (Harvard)

[11] Appl. Phys. Lett. **117**, 114002 (2020) Sasaki *et al.* (Keio)